

# Shrewsbury Town Centre Design Code

April 2026



SHREWSBURY



BIG TOWN PLAN



Version: 2

Date: 7 April 2026

Comment: Final Report

This document has been prepared and checked in accordance with ISO 9001:2015



# Table of Contents

## Volume 1

<b>Introduction</b>	<b>4</b>		
Design Vision	12		
Understanding Shrewsbury Town Centre's Character	14		
<b>Design Code</b>	<b>20</b>		
<b>Movement</b>	<b>22</b>	<b>Identity</b>	<b>42</b>
M01 Streets	22	I01 Local Character	42
M01.1 Enhanced Streets design considerations:	24	I02 Composition and building articulation	42
M01.2 Informal streets design considerations:	24	I03 Roof form	44
M01.3 Pedestrian Priority Streets design considerations:	25	I04 Materials and details	45
M01.4 Riverfront Streets design considerations:	25	I05 Windows	45
Active Travel	26	<b>Public Space</b>	<b>46</b>
M02 Active Travel	27	P01 Public realm	46
M03 Parking	28	P02 Safety and security	47
M03.1 Courtyard Parking	29	P03 Play	48
M03.2 Basement & Undercroft Parking	29	P04 HVM	49
M03.3 Surface Parking:	30	<b>Uses</b>	<b>50</b>
M03.4 On Street Parking	30	U01 Mix	50
M04 Servicing, utilities, refuse and recycling collection	31	U02 Active frontages	50
<b>Green Infrastructure</b>	<b>32</b>	<b>Homes</b>	<b>51</b>
N01 Green Infrastructure	32	H01 Residential quality	51
N02 Roofs and walls	34	H02 Gardens and balconies	52
N03 Trees	34	H03 Detailing	52
N04 Sustainable Drainage	36	<b>Resources</b>	<b>53</b>
N05 Biodiversity	37	R01 Passive design and orientation	53
<b>Built Form</b>	<b>38</b>	R02 Solar energy generation	53
B01 Scale	38	R03 Windows, shading and cooling	54
B02 Variety	39	Sustainable Construction	54
B03 Tall buildings	39	R04 Environmental standards	54
B04 Responding to topography	40	R05 Retrofitting	54
B05 Urban grain and block articulation	40	R06 Embodied energy	55
		R07 Operational/whole life energy	55
		R08 Modern methods of construction	55
		R09 Water saving	55
		<b>Delivering Design Excellence</b>	<b>56</b>
		Required Information	61

# Introduction

This Design Code sets out an aspiration for high quality design throughout Shrewsbury town centre, establishing a new standard for placemaking.

It provides overarching design and place-making coding for new development (new buildings and spaces) in Shrewsbury town centre thereby supporting the understanding and application of design policies in the adopted Development Plan for Shropshire. Its primary purpose is to ensure that new development respects and enhances local character, whilst setting a benchmark for design quality and place-making.

## **The National Design Guide**

The National Planning Policy Framework (NPPF) makes clear that creating high quality buildings and places is fundamental to what the planning and development process should achieve. The National Design Guide and National Model Design Code were published to set a national framework for the delivery of high quality design in new developments across the country.

The underlying purpose of these documents is to enhance design quality and the quality of new development at all scales in order to create well designed and well-built places that benefit people and communities.

They help local planning authorities and communities decide what good quality design looks like in their area based on the local aspirations for how it should develop.

This Design Code has been prepared to align with the ten characteristics of well-designed places, as set out by The National Design Guide and National Model Design Code (NMDC).

## **Purpose of the Design Code**

The Design Code sets out the aspiration for design quality and place-making throughout Shrewsbury town centre. In this way it provides a clear framework for both designers and decision makers, to shape the high quality design of new development within the town centre.

It will be used as a tool by the local planning authority alongside its material consideration status to determine planning applications within Shrewsbury town centre - supporting the understanding and application of design policies in the adopted Development Plan for Shropshire in this area. Applicants and their designers will need to demonstrate compliance with this document when proposing new development in Shrewsbury town centre.

## **Where the Code applies**

This Design Code applies throughout Shrewsbury town centre as defined in The Big Town Plan.

It is also responsive to the 6 character areas of the town centre defined by The Big Town Plan, particularly within the Shrewsbury Conservation Area, both of which are shown on the diagram on the next page.

KEY







- |   |                       |   |                  |   |                              |
|---|-----------------------|---|------------------|---|------------------------------|
|  | Northern Corridor     |  | The West End     |  | Shrewsbury Conservation Area |
|  | Station Quarter       |  | Historic Quarter |   |                              |
|  | Riverside & Frankwell |  | Abbey Foregate   |   |                              |



Figure 1 Shrewsbury town centre character areas as defined in the Big Town Plan with the hatching denoting the Shrewsbury Conservation Area.

## **Who is the Design Code for?**

The Design Code will inform and guide the design and place-making of all new development within Shrewsbury town centre. It is therefore intended to be read by a wide range of stakeholders. The main groups can be set out as:

### **Applicants**

The Design Code is intended to give all those applying for planning consent (whether planner, architect, designer, developer or landowner) for new development within Shrewsbury town centre with clear standards for design and place-making expectations thereby supporting their understanding of design policies in the adopted Development Plan for Shropshire. It will also provide a 'common language' and understanding for what is required and the level of expectation when proposing new development in Shrewsbury town centre.

### **Planning Officers**

The Design Code will be a 'tool' used by Shropshire Council planning officers during pre-application and planning application processes, supporting the review of the design and place-making credentials of proposed new development in Shrewsbury town centre. In this way it supports the application of design policies in the adopted Development Plan for Shropshire and helps ensure consistent design advice is provided throughout the planning process.

### **Planning Committee**

As a material planning consideration, the Design Code will also be used by Shropshire planning committees when undertaking decision making on planning applications in Shrewsbury town centre.

### **Residents and Stakeholders**

The Design Code forms part of the framework to achieve high quality design and effective place-making in Shrewsbury town centre. As such, it will provide town centre residents and other stakeholders with greater certainty on the design standards new development should meet.

### **For Investors**

The Design Code can also be used as a marketing tool, communicating future aspirations for design quality within the town centre and how important sense of place, the environment and sustainability are to the Council, its partners, stakeholders and the community.

## **Using this Design Code**

The intention of the Design Code is to deliver an easy to use set of design standards for new development in Shrewsbury town centre.

These design standards support the understanding and application of the wider design policies in the adopted Development Plan for Shropshire.

## **Understanding Shrewsbury Town Centre's Character**

The Design Code first sets out the key characteristics which define Shrewsbury's distinctive town centre and as such should inform the design of new development within it.

### **Design Code**

The Design Code then identifies a series of 'themes'. Each theme has an Expected Design Outcome providing a clear description of what the Council is trying to achieve through the coding.

Each theme also provides coding to support the understanding and application of design policies in the adopted Development Plan for Shropshire within Shrewsbury town centre. Applicants and developers are expected to consider these standards from initial deliberation, through to project design, during the planning application process, and throughout construction.

As such, planning applications for new development within Shrewsbury town centre should be supported by a completed **Design Code Checklist**.

### **Design Code Checklist**

This Design Code includes a self-assessment checklist, which supports applicants and planning officers when considering the design and place-making credentials of proposed new development in Shrewsbury town centre.

As such it should be completed and submitted alongside a planning application, thereby streamlining the decision making process.

## **Comply or Justify**

The requirements set out within this Design Code have been developed under the principle of "comply or justify".

This means there is a general expectation that the preparation of development proposals for Shrewsbury town centre will follow the guidance standards as set out within this document. In doing so, such proposals are more likely to proceed through the planning process more quickly and successfully.

Where such a proposal departs from any of the code, a thorough justification should be provided, detailing reasons for the alternative approach. In doing so, reference will be made to how it responds to the character of Shrewsbury town centre and each of the design code 'themes'.

Compliance or justification of an alternative approach should be documented within the **Design Code Checklist**.

The intention of this approach is not to stifle creativity, which is actively encouraged and facilitated by this Design Code. Rather it is to ensure that new development in Shrewsbury town centre positively responds to its unique characteristics, achieves a high-quality design and supports place-making – in accordance with the policies of the adopted Development Plan.

As a result, failure to pay due regard to this Design Code may result in a planning application being refused on design grounds.

## Planning and Background Context

### National Level

The National Planning Policy Framework (NPPF) requires local planning authorities to prepare design guides or codes consistent with the principles set out in the National Design Guide and National Model Design Code. These documents should reflect local character, design preferences, and provide a framework for creating beautiful and distinctive places.

According to the NPPF, a Design Code is ‘a set of illustrated design requirements that provide specific, detailed parameters for the physical development of a site or area’.

An emphasis on good design is embedded in the planning process, and the National Design Guide and National Model Design Code provide planning guidance for beautiful, enduring, successful places.

The National Design Guide and National Model Design Code set out 10 characteristics of well-designed places (as detailed below); provide definitions and good practice examples of design considerations and explain that specific, detailed and measurable criteria for good design are most appropriately set out at the local level through local design policies, design guides, or design codes.

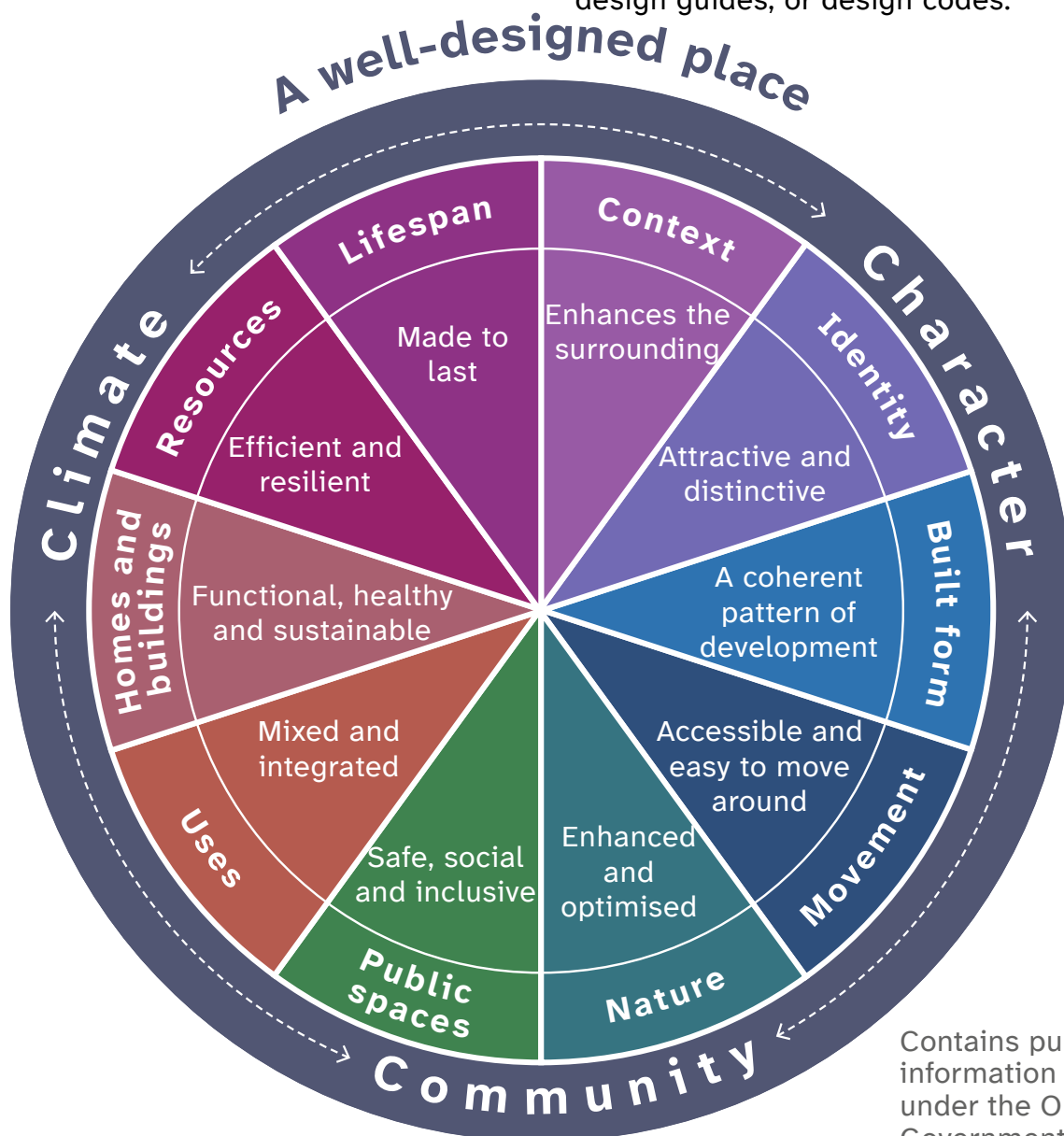

Contains public sector information licensed under the Open Government Licence v3.0.

## Local Level

This Design Code supports the understanding and application of design policies in the adopted Development Plan.

The adopted Development Plan for Shropshire consists of:

- The adopted Local Plan which collectively covers the period 2006-2026 and comprises:
  - The Core Strategy (2011) which sets out the vision, strategic objectives, broad spatial strategy, and strategic policies.
  - The Site Allocations and Management of Development (SAMDev) Plan (2015) which provides detailed ‘development management’ and ‘settlement’ policies to guide future development and identifies allocations.
- ‘Made’ Neighbourhood Development Plans:
  - Currently nine made Neighbourhood Plans and several more in preparation.

Importantly, the adopted Local Plan will remain part of the Development Plan until a new Local Plan is adopted.

Policies CS2 of the Core Strategy and S16.1 of the SAMDev Plan collectively establish the development strategy for Shrewsbury.

These policies ensure a comprehensive and co-ordinated approach is pursued to the planning and development of Shrewsbury, including its town centre. The objectives of the “Big Town Plan” and its associated masterplan documents also align with this development strategy.

Policies CS6 of the Core Strategy and MD2 of the SAMDev Plan specifically address Sustainable Design Principles:

## CS6: Sustainable Design & Development Principles

Establishes the expectation that to create sustainable places, development will be designed to a high quality using sustainable design principles, to achieve an inclusive and accessible environment which respects and enhances local distinctiveness and which mitigates and adapts to climate change.

## MD2: Sustainable Design

Requires development to:

- Contribute to and respect locally distinctive or valued character and existing amenity values by:
  - i. Responding appropriately to the form and layout of existing development and the way it functions, including mixture of uses, streetscape, building heights and lines, scale, density, plot sizes and local patterns of movement; and
  - ii. Reflecting locally characteristic architectural design and details, such as building materials, form, colour and texture of detailing, taking account of their scale and proportion; and
  - iii. Protecting, conserving and enhancing the historic context and character of heritage assets, their significance and setting, in accordance with MD13; and
  - iv. Enhancing, incorporating or recreating natural assets in accordance with MD12.
- Embrace opportunities for contemporary design solutions, which take reference from and reinforce distinctive local characteristics to create a positive sense of place, but avoid reproducing these characteristics in an incoherent and detrimental style.
- Consider design of landscaping and open space holistically as part of the whole development to provide safe, useable and well-connected outdoor spaces which respond to and reinforce the character and context within which it is set.

Other Design-related documents that provide background information and requirements for development in Shrewsbury town centre are:

- A. Shrewsbury Big Town Plan Spatial Development Framework (SDF) 2018
- B. Shrewsbury Big Town Plan Masterplan Vision (2020)
- C. Smithfield Riverside Development Framework (2022)
- D. West Midlands Design Charter (2020)
- E. Shrewsbury Movement and Public Space Strategy (2024)
- F. Shropshire Climate Change Strategy (2020) and Action Plan (2020)
- G. Shropshire Green Infrastructure Strategy (2020)

## Glossary and Definition of Terms

There are a number of terms used within this Design Code and to ensure their definitions remain accurate over time these are best defined within the Shropshire Council's planning portal and on the Government's National Planning Policy Framework (NPPF) website on the links below:

# Design Vision

“Higgledy-piggledy streets with names you want to say out loud- Grope Lane, Wyle Cop. A river that scoops up the town in a perfect loop. Wonky buildings left right and centre. 14th century graffiti. Three million blooms in a quarry. Shops you’ve never seen or heard of in your life.

You can’t copy Shrewsbury.”

A Shrewsbury Story, Shrewsbury BID

## Rooted in heritage, sights set firmly on the future, a one-off town.

From its beginnings as a defended settlement and trading town within the loop of the River Severn, Shrewsbury has evolved to become an attractive place to live, work and enjoy. Whilst this town has always brought people together, its intricate network of medieval streets and spaces offer intrigue around every corner as well as featuring a unique blend of building styles that together create an unrivalled sense of place.

This Design Code sets out how design can contribute to the delivery of an equitable, sustainable, and beautiful town centre. Design in Shrewsbury town centre should be approached positively, focused around delivering a great place to live, visit and work. Design in Shrewsbury town centre should be:

- Characterful
- Healthy
- Connected
- Green
- Varied
- Sustainable
- Engaged





Figure 2 Visual representation of the Design Vision for Shrewsbury town centre.

# Understanding Shrewsbury Town Centre's Character

The following section sets out the key characteristics which define this distinctive town centre. A Design Code on how to address these characteristics is set out in the rest of this document.

## Key Characteristic:

### 1. Landform and topography

Dramatically nestled within a loop of the River Severn, the town centre rises to form two hills, which historically made it an excellent place to build a defensible settlement site on the English/ Welsh border. Its town walls and selected access points across the river enclose a tight medieval pattern of streets and spaces, that have largely remained intact. Shrewsbury's skyline is highly visible with spires acting like beacons due to these important buildings being erected on high points within the river loop and are often revealed when moving around the town.

### 2. Strong Relationship to the River Severn

Shrewsbury is almost wholly encircled by the River Severn creating a unique and defining characteristic of the town centre. The original settlement grew from establishing fordable river crossings and later bridges, which provided opportunities for defence and trade on the borders of Wales. The significance of the English and Welsh Bridges, with the latter replacing the former St George's Bridge to its north, are apparent today. Whilst the river is significant in shaping the town centre, it also floods and has had an impact on lower lying areas in Riverside and Frankwell. Consequently, there is a need to create a positive relationship with the river balanced against the potential impacts of future climate change.



Figure 3 View down Wyle Cop showing historic development responding to landform.



Figure 4 View of the River Severn from the Quarry illustrating its direct relationship with the town facilitating access and movement.

### 3. Fine urban grain

The structure of the town centre is based on a dense medieval street pattern that, with its fine urban grain, is reflected in the extensive network of historic streets which feature a variety of buildings on long, narrow “Burgage” plots. These form almost continuous frontages. This is further complemented by a series of narrow passageways or ‘Shuts’ offering alternative access for pedestrians to places hidden from immediate view, creating a sense of drama and discovery. Whilst the fine urban grain remains largely intact across the town centre, there are areas where it has been lost or never developed, such as Riverside.

### 4. A ‘Green’ town

Whilst the local community value the numerous open spaces that contribute greatly to the overall perception of Shrewsbury as being a ‘green town’ there are two significant areas of parkland used primarily for recreation and leisure. These are the Quarry and Frankwell fields, both of which are adjacent to the River Severn and feature extensive tree cover, with the Quarry offering a more structured and formal arrangement of planting reflecting its status as a Historic Park and Garden. Within the remainder of the town, green infrastructure is limited to street trees and smaller open spaces, but is further emphasised by the array of formal planters and hanging baskets reflecting the town’s reputation as a “Town of flowers”.



Figure 5 View down High Street showing a dense urban grain.



Figure 6 Small pocket green spaces are found in the town centre.

## 5. A network of public spaces

Public space within the town centre is typically well defined, enclosed and located on key streets. The principal hard paved space is The Square. Shrewsbury's town centre public spaces are often directly related to landmark buildings. These spaces provide opportunities for trees and planting. Internal private courtyards are also a feature of the urban form.

## 6. Human scale

Whilst Shrewsbury's buildings typically offer a continuous and active frontage, their height is of a modest scale, between 2-4 storeys. This human scale provides a level of enclosure to the street without being overbearing and makes it possible to see decoration and detail. Where there are taller buildings or where parts of a building's structure extends upwards beyond the roofline (such as a steeple or tower) they have become established landmarks in Shrewsbury town centre's distinctive skyline.



Figure 7 The Square a key public space.



Figure 8 Human scale buildings - High Street and Milk Street.

## 7. Celebration of Landmark Buildings

The range and diversity of Shrewsbury's buildings, some part hidden behind later frontages, has created a rich tapestry of defined, revealed, sequential or glimpsed views. This heightens the sense of drama and discovery on moving around the town centre. Many of these buildings have become local landmarks providing important reference points for wayfinding and navigation as well as a creating a defining character and sense of place.

## 8. Variety and Contrast

The diversity of building types, architectural style, materials, scale and massing has created a rich variety of form, contrast and decoration within the town centre, ranging from medieval timber framed, through to Georgian, Victorian and 20th century architecture. Despite variety and contrast being a feature of many streets, the most successful are those characterised by a degree of cohesion through regularity of plot widths or materials.



Figure 9 View down Claremont Hill with St Mary's Church spire.



Figure 10 Variety of buildings along High Street.

## 9. Verticality

The fine urban grain typically creates a regular vertical rhythm of elements along the street, that is often expressed by the change from one building to another on narrow plots. The vertical characteristics are also reinforced by the regular positioning of windows and doors, as well as dormers, generally aligned to emphasise the height of the building rather than its width along the street. Many contemporary buildings within Shrewsbury town centre have found creative ways to preserve this vertical characteristic, through dividing elevations into vertical segments, despite occupying modern floor plates.

## 10. Varied roofscape

Shrewsbury town centre's skyline is an important characteristic emphasised by the underlying topography. The assorted roof forms, which are primarily pitched, have in places created a cascade of varying ridge lines, gables, chimneys and dormers, complemented by brick parapets and cornices of later Georgian buildings. This has led to the creation of distinctive and dramatic views of the town with the variety of built form adding another layer of richness at a distance, that is not always apparent at street level.



Figure 11 Verticality expressed across the building facades, St John's Hill.



Figure 12 View of Shrewsbury's roofscape with St Alkmund's Church spire and St Julian tower.

### 11. Definition of the Base, Middle and Top

Many buildings within the historic town centre have distinct definition between their base, middle and top. This is expressed through architectural detailing, material changes and/or massing articulation.

### 12. Intricate patterning and detailing

The buildings across Shrewsbury town centre are rich in architectural details and pattern. Timber framed buildings feature the unique style of the ‘Shrewsbury School of Carpentry’ and stone buildings feature decorative pediments and cornices which also provide accents for historic brick buildings. The patterns featured on these buildings are typically carved or are manufactured locally and continue to be a source of inspiration for detailing modern contributions to the townscape.

Standards for how proposals should appropriately respond to these characteristics are set out in themes covered in the next section.

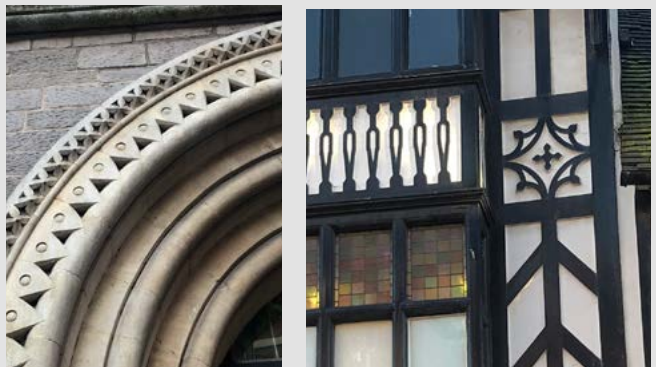
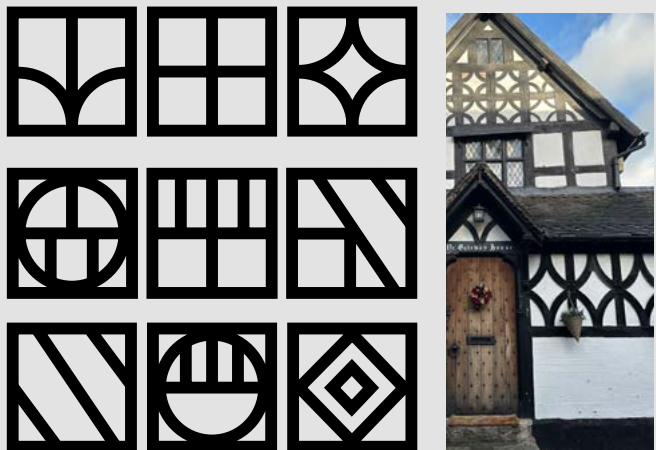

Figure 13 A collage of photographs and graphics presenting patterns and detailing on Shrewsbury’s buildings.

# Design Code





# Design Code Contents

<b>Movement</b>	<b>22</b>	<b>Identity</b>	<b>42</b>
<b>M01 Streets</b>	<b>22</b>	<b>I01 Local Character</b>	<b>42</b>
M01.1 Enhanced Streets design considerations:	24	<b>I02 Composition and building articulation</b>	<b>42</b>
M01.2 Informal streets design considerations:	24	<b>I03 Roof form</b>	<b>44</b>
M01.3 Pedestrian Priority Streets design considerations:	25	<b>I04 Materials and details</b>	<b>45</b>
M01.4 Riverfront Streets design considerations:	25	<b>I05 Windows</b>	<b>45</b>
Active Travel	26	<b>Public Space</b>	<b>46</b>
<b>M02 Active Travel</b>	<b>27</b>	<b>P01 Public realm</b>	<b>46</b>
<b>M03 Parking</b>	<b>28</b>	<b>P02 Safety and security</b>	<b>47</b>
M03.1 Courtyard Parking	29	<b>P03 Play</b>	<b>48</b>
M03.2 Basement & Undercroft Parking	29	<b>P04 HVM</b>	<b>49</b>
M03.3 Surface Parking:	30	<b>Uses</b>	<b>50</b>
M03.4 On Street Parking	30	<b>U01 Mix</b>	<b>50</b>
<b>M04 Servicing, utilities, refuse and recycling collection</b>	<b>31</b>	<b>U02 Active frontages</b>	<b>50</b>
<b>Green Infrastructure</b>	<b>32</b>	<b>Homes</b>	<b>51</b>
<b>N01 Green Infrastructure</b>	<b>32</b>	<b>H01 Residential quality</b>	<b>51</b>
<b>N02 Roofs and walls</b>	<b>34</b>	<b>H02 Gardens and balconies</b>	<b>52</b>
<b>N03 Trees</b>	<b>34</b>	<b>H03 Detailing</b>	<b>52</b>
<b>N04 Sustainable Drainage</b>	<b>36</b>	<b>Resources</b>	<b>53</b>
<b>N05 Biodiversity</b>	<b>37</b>	<b>R01 Passive design and orientation</b>	<b>53</b>
<b>Built Form</b>	<b>38</b>	<b>R02 Solar energy generation</b>	<b>53</b>
<b>B01 Scale</b>	<b>38</b>	<b>R03 Windows, shading and cooling</b>	<b>54</b>
<b>B02 Variety</b>	<b>39</b>	<b>Sustainable Construction</b>	<b>54</b>
<b>B03 Tall buildings</b>	<b>39</b>	<b>R04 Environmental standards</b>	<b>54</b>
<b>B04 Responding to topography</b>	<b>40</b>	<b>R05 Retrofitting</b>	<b>54</b>
<b>B05 Urban grain and block articulation</b>	<b>40</b>	<b>R06 Embodied energy</b>	<b>55</b>
		<b>R07 Operational/whole life energy</b>	<b>55</b>
		<b>R08 Modern methods of construction</b>	<b>55</b>
		<b>R09 Water saving</b>	<b>55</b>

# Movement

## Expected Design Outcome:

A town centre where vehicular traffic has been significantly reduced and the focus of streets is on walking, wheeling, cycling and place.

The adopted Shrewsbury Movement and Public Space Strategy (2024) provides detailed guidance on movement and the design of streets in Shrewsbury Town Centre.

## Streets

Consistent with the Chartered Institution of Highways and Transportation (CIHT) guidance for creating inclusive and accessible streets, the aspiration is that all streets in the town centre align with one of the following typologies:

1. Enhanced Streets
2. Informal Streets
3. Pedestrian Priority Streets
4. Riverfront Street

Aligning existing streets with one of these street typologies will be supported by the implementation of the Shrewsbury Movement and Public Space Strategy. It is acknowledged that in the meantime there will remain some 'traditional' streets which follow a conventional design, often prioritising the car.

A useful way of thinking about streets is placing them in a hierarchy, considering first their ability to contribute to place-making, followed by their movement characteristics.

These factors have informed the street typologies envisaged in Shrewsbury town centre, reflecting the differing roles streets have across the town centre.

The following pages outline the key design

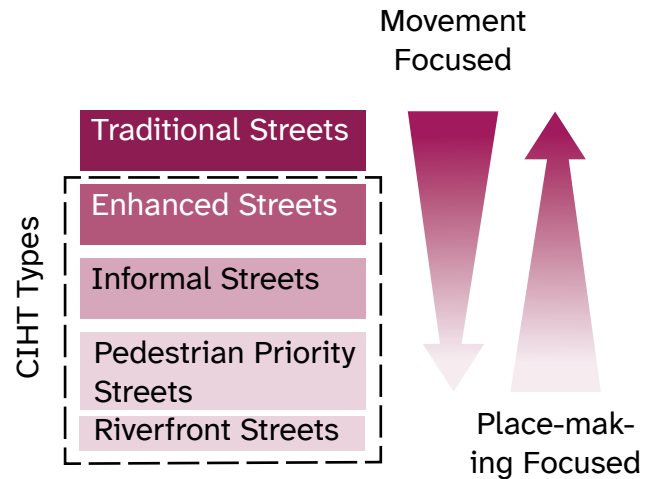

considerations for each street type and applicants are advised to carefully consider the types of street they are addressing and/or creating within their development.

### M01 Streets

- A. Applicants should establish street type(s) their proposal interfaces with and then demonstrate how their proposals respond to the design considerations for such street type(s), as set out in this section. This can be informed by the pre-application process.
- B. Where applicants are proposing new streets within or around their proposal, they should clearly evidence the street type(s) proposed and the reasoning for their inclusion prior to agreeing these with the Council.
- C. Where no new streets are proposed, applicants should consider the street they adjoin/ face onto and how their development should address them to support its place-making and movement function.

## Future Street Typologies

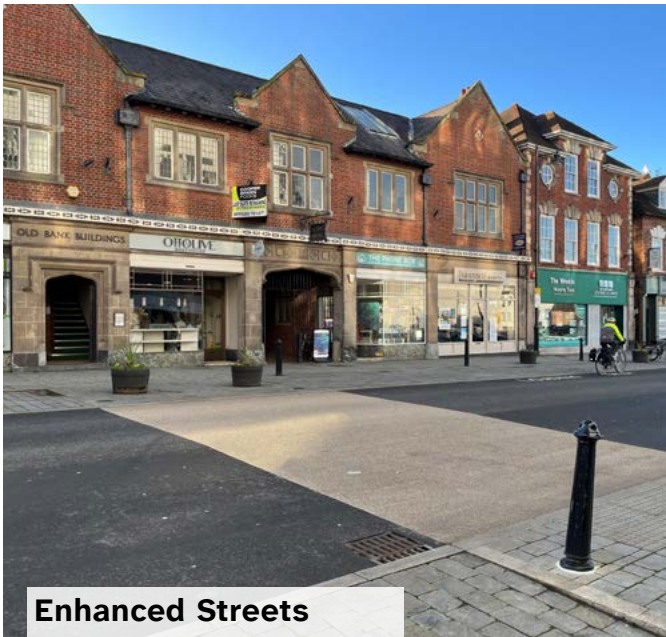

**Enhanced Streets**

Figure 14 Enhanced Streets are streets where the public realm has been improved and restrictions on pedestrian movement (e.g. guardrails etc) have been removed but conventional traffic controls largely remain.



**Informal Streets**

Figure 15 Informal Streets accommodate traffic, but at slower speeds, and offer increased space for pedestrians and cyclists. Formal traffic controls are absent or reduced. There is a footway and carriageway, but typically there is less differentiation between them such that it is typically less than in a conventional street.



**Pedestrian Priority Streets**

Figure 16 Pedestrian Priority Streets are where pedestrians feel able to move freely and safely anywhere, such that they feel a guest. These streets will typically feature seating and planting with spill out space from the building edge.



**Riverfront Streets**

Figure 17 Riverfront Streets are Pedestrian Priority Streets but they are located on the riverfront edge, and have different place-making priorities associated with the river.

## Enhanced Streets

Role: A movement priority street with public realm enhancement.



Figure 18 A typical section of an enhanced street.

### M01.1 Enhanced Streets design considerations:

- A. The focus of the street should be on accommodating a good balance between pedestrians, cyclists and vehicles.
- B. Separation between pedestrians and cyclists using guidance from LTN 1/20, buff colours should be used for cycle ways.
- C. Adequate lighting to allow safe vehicular, pedestrian and cycle movement.
- D. Bus stands, bins, seating and other street furniture to be accommodated carefully to avoid clutter.
- E. The use of highway barriers should be minimised and used only where absolutely necessary.
- F. Streets provide important opportunities for green connectivity and enhancement of Shrewsbury's Green Infrastructure network. To achieve this, landscape features (planting, street trees, SuDS, green walls / façades) should be considered along primary routes in support of Shrewsbury's character as a 'Green Town' - refer to N01 Green Infrastructure

## Informal Streets

Role: A balance between movement and place function.

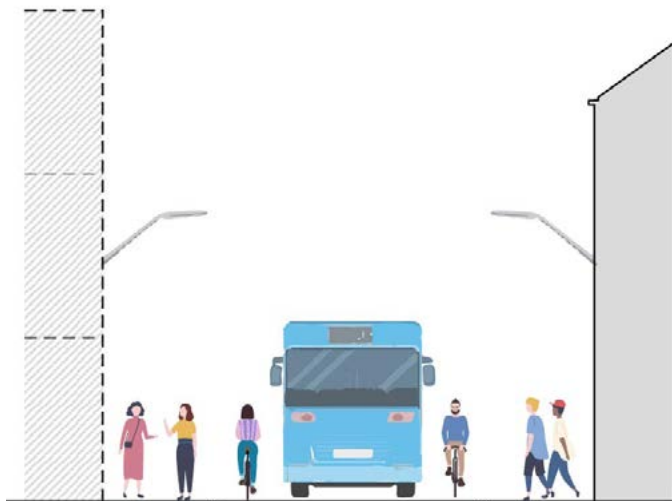

Figure 19 A typical section of an informal street.

### M01.2 Informal streets design considerations:

- A. These streets accommodate moderate levels of traffic at slow speeds.
- B. They are often bus corridors and should be designed to facilitate safe and efficient bus, cycle and pedestrian movement.
- C. Informal streets have good levels of pedestrian and cycle movement, often to allow access to local businesses and so achieving a high quality pedestrian and cycling experience should be a priority.
- D. On street parking should be for disabled use only.
- E. Street lighting should be designed to reflect local character and, where possible, be mounted to buildings.
- F. Servicing of businesses and residents streets should be carefully considered and effectively managed.
- G. Where possible SuDS should be incorporated within the street scene.

## Pedestrian Priority Streets

Role: Priority on place and people rather than movement.

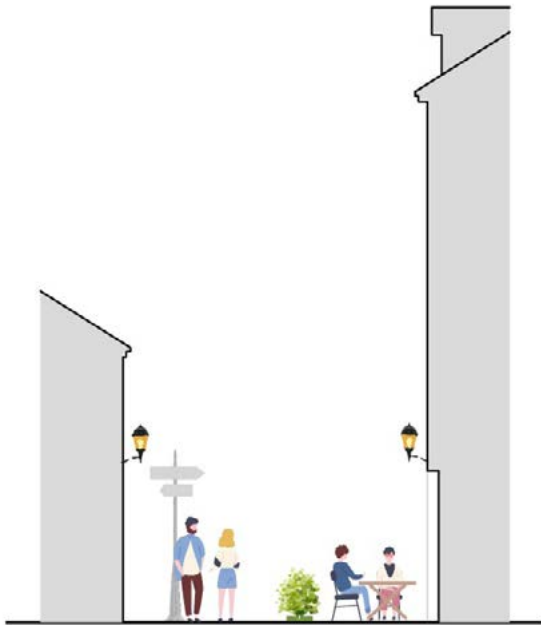

Figure 20 A typical section of a Pedestrian Priority Street.

## Riverfront Streets

Role: Priority on place and people rather than movement and defined by its relationship to River Severn.



Figure 21 A typical section of a riverfront street.

### M01.3 Pedestrian Priority Streets design considerations:

- A. These streets are designed primarily for the pedestrian to deliver a pleasant, safe and legible experience for all such users.
- B. Streets can be made available for service and other priority access vehicles but only for limited periods during the day.
- C. Sufficient protection at entrances to the street should be considered through careful landscaping, however the use of large areas of bollards should be avoided.
- D. Fixed and movable seating should be incorporated into the street. Planters offer value but ideally should be integrated into the seating, to reduce clutter.
- E. Wayfinding and interpretation should be carefully incorporated at key junctions and entrances, being careful to avoid clutter.
- F. Appropriate species of street trees should be integrated to enhance the streetscape and provide shade for pedestrians where space and other constraints allow.

### M01.4 Riverfront Streets design considerations:

- A. The focus of the street should be on the pedestrian and cyclist experience.
- B. Careful consideration should be given to the safety of people near the river through the design of the public realm and considered alongside flooding constraints.
- C. Opportunities to step down to the river using enhanced landscaping, pontoons or terracing should be prioritised.
- D. Where necessary for servicing or access, vehicular movement should be controlled and limited at certain times to promote pedestrian safety.
- E. Where possible, landscape features should be incorporated into the street scene, suitable for its context, to enhance GI.
- F. Maximise opportunities to provide places to sit and dwell and to accommodate spill-out space from cafés and bars bringing activity to the street.
- G. Low level accent lighting and task lighting should be prioritised over highways lighting.

# Active Travel

The overall vision is for a healthy and active town centre where walking, wheeling and cycling are the first choice for movement. It is anticipated that this can be promoted through the design and layout of any new development by ensuring inclusive design principles are followed. This includes consideration of how routes work for mobility aids such as wheelchairs, pushchairs, and acknowledge steeper gradients.

Shrewsbury will follow an active travel first approach to movement, prioritising active and sustainable movement over the use of the private car. The following Movement Hierarchy underpins the approach to movement and access in Shrewsbury.



Figure 22 Opportunities to design in landscape to segregated cycle lanes should be promoted wherever possible.

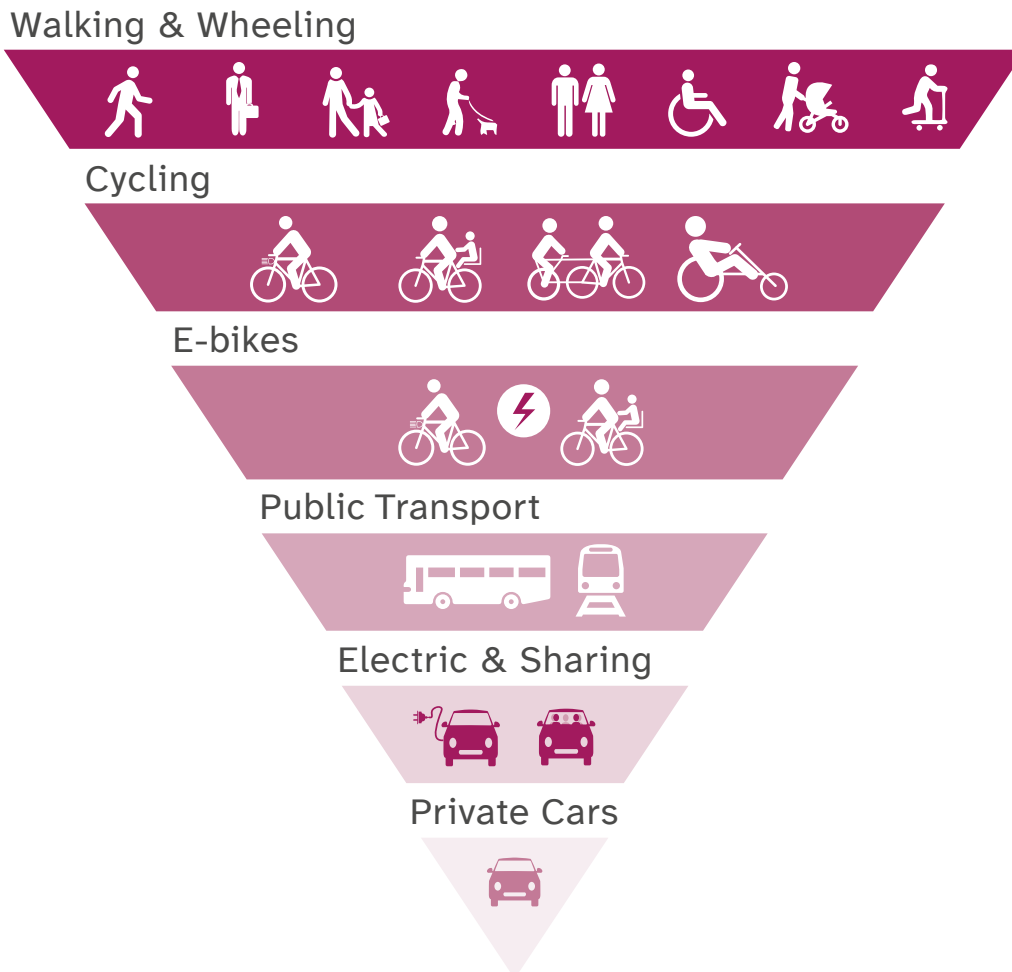

Figure 23 The Shrewsbury Movement Hierarchy.

## M02 Active Travel

- A. Applications should clearly outline how they respond to figure 23 the Shrewsbury Movement Hierarchy, defining how they prioritise and facilitate active travel over the use of the private car.
- B. New development should actively promote pedestrian and cycle movement by contributing to the creation of direct pedestrian and cycle routes which benefit from natural surveillance.
- C. New developments should connect to existing walking and cycling networks to avoid isolated routes.
- D. Streets should be designed to be inclusive and cater to the needs of all users as far as possible considering the needs that may relate to disability, age, gender and maternity.
- E. Junctions should be designed in accordance with Manual for Streets to be safe, convenient, and attractive for all users and aligned with desire lines.
- F. Any cycle stands proposed on street or in the public realm should not obstruct people movement or contribute to cluttering of streets. Visitor cycle parking associated with a building should be located as close as possible to the main entrance, without obstructing movement.
- G. Pedestrian crossings should retain a sense of ownership, be located on desire lines, avoid unnecessary clutter and be single stage where possible.
- H. Private cycle parking/storage should be integrated into the design of buildings, where possible. Where it is not, storage areas should be covered, secure and within close proximity to the building entrance and within the plot curtilage.
- I. Both cycle store and individual bike stands should be lockable.
- J. Structures associated with active travel, like cycle shelters, should consider including green roofs or façades to enhance Shrewsbury's green infrastructure and biodiversity. Refer to N02 Green Roofs and Walls.

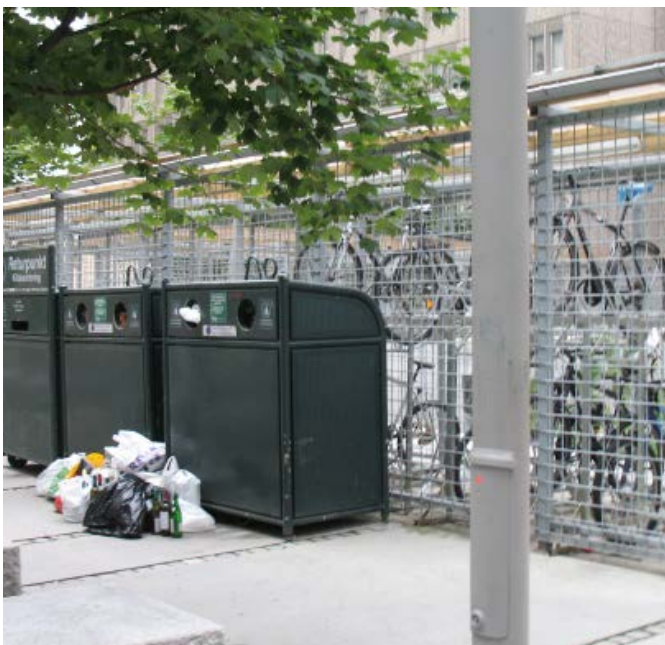

Figure 24 Covered and secured cycle parking located in close proximity to the building.



Figure 25 New development should actively promote pedestrian and cycle movement.

# Parking

Parking can have a significant impact on the function and appearance of a development proposal and streetscape. The aspiration for Shrewsbury town centre, is to deliver a modal shift in behaviour, resulting in less need for high levels of car parking in the future, while reducing the impact of on-street parking on the town centre. This section outlines the best possible way to integrate required car parking (proposed or re-designed existing), into development proposals for new buildings or spaces.

Typical parking typologies appropriate for Shrewsbury town centre are outlined on the following page.



Figure 26 Courtyard parking arrangements.

## M03 Parking

- A. Car Parking should be designed to be safe, attractive to use and in convenient locations.
- B. The location of car parking should be carefully considered to ensure it does not detract from the appearance of buildings and spaces, limit active frontages, or disrupt access to the ground floor.
- C. Car parking areas should carefully consider surface treatment and, where possible, incorporate permeable materials.
- D. EV charging points should be located across the town centre in accessible locations to promote the use of electric cars. EV charging points should be designed into the public realm, be visible but sensitive to local character, and not obstruct people movement or contribute to cluttering of streets.
- E. Design should have minimal impact on the townscape. The use of car clubs is encouraged to reduce parking requirements related to new development.
- F. Disabled and car club parking spaces should be prioritised and co-located with entrances.



Figure 27 Surface car parking incorporating high quality landscape and SuDS.

- G. Large areas of car parking (over 10 spaces) should incorporate both edge and internal landscaping features (including SuDS) and provide clear pedestrian routes to support integration into the townscape.

## Courtyard parking

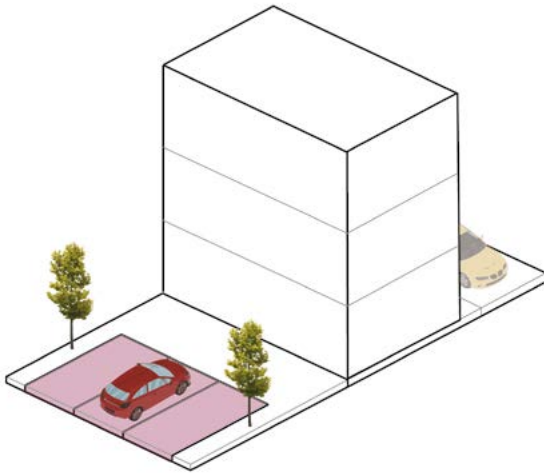

Figure 28 Courtyard parking.

### M03.1 Courtyard Parking

- A. Courtyard parking may be appropriate to serve groups of businesses and homes for residents or visitors where no allocated bays.
- B. Should be located within blocks overlooked by buildings.
- C. Should be limited in scale and arranged in clusters.
- D. Should be well lit and designed to provide safe access and egress for people as well as cars.
- E. Landscaping and walking routes should be used to frame and mitigate the visual impact of parking.
- F. The use of appropriate species of trees is encouraged where constraints allow. This may entail use of specialist tree pits, appropriate surrounding surfaces and irrigation systems to ensure survival of the planted trees to maturity.

## Basement & Undercroft Parking

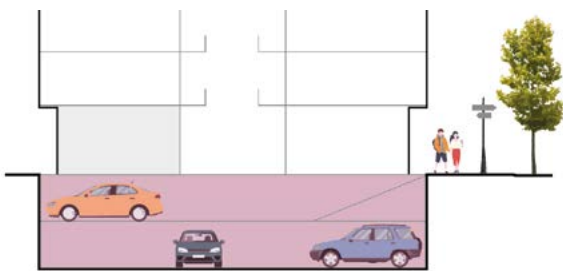

Figure 29 Basement parking.



Figure 30 Undercroft parking.

### M03.2 Basement & Undercroft Parking

- A. Basement and undercroft parking is appropriate in larger mixed use and residential blocks.
- B. Can provide residential and non residential parking, including visitor parking.
- C. Should be incorporated into the design of the building to allow for safe access and egress for people as well as cars.

## Surface parking

Car parks over 20 spaces.

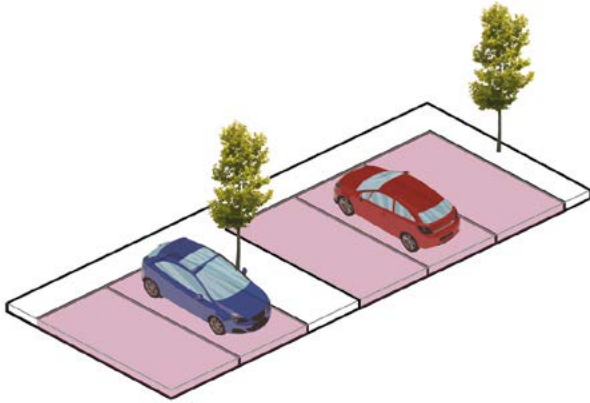

Figure 31 Surface parking.

## On Street parking

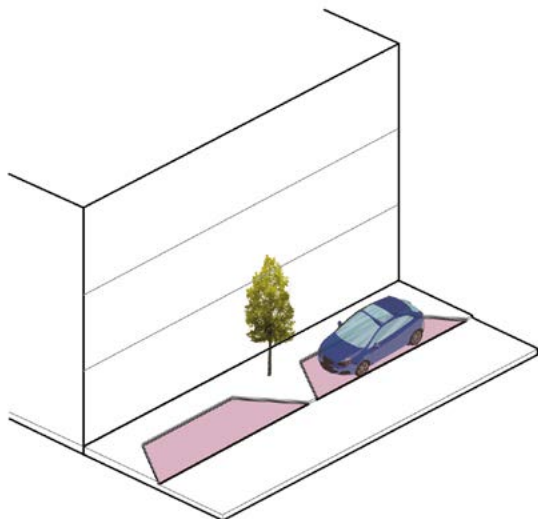

Figure 32 On street parking.

### M03.3 Surface Parking:

- A. Proposals for new large areas of surface parking should be avoided and are not considered appropriate within the immediate town centre area.
- B. In the limited circumstances where such parking is appropriate, it will be to support proposals for new retail or commercial (including leisure) development and will need to be fully justified through the application process.
- C. Where areas of new surface-level parking are necessary, they should be of the minimum size and plot needed, and be located towards the rear of the development plot or block and away from the main street frontage to allow for an active frontage.
- D. Planting, including a grid of trees between bays, is also encouraged. This may entail use of specialist tree pits, appropriate surrounding surfaces and irrigation systems to ensure survival of the planted trees to maturity
- E. Short-term visitor parking may be positioned on-street or close to building frontages.

### M03.4 On Street Parking

- A. Where car parking is provided on street, it should be broken up into groups of a maximum of three bays separated by build outs which provide opportunities for pedestrians to cross and for landscaping, ensuring good visibility of the street.
- B. New on street parking should be for Blue Badge parking only.
- C. Adequate areas for drop off, deliveries and servicing should be provided on street and be located close to entrances and away from key pedestrian desire lines. It should incorporate appropriate landscaping to mitigate its visual impact.

# Servicing, utilities, refuse and recycling collection

## M04 Servicing, utilities, refuse and recycling collection

- A. New development should integrate the requirements of utility providers, refuse collection and emergency access without compromising the quality of place by obstruction of movement or visual intrusion.
- B. All new development needs to be accessible to emergency vehicles, with early engagement with the Emergency Services encouraged. Sites with limited vehicular access points need to ensure that ambulances and fire tenders can gain access if one of the roads is blocked.
- C. New utilities should be aligned in shared ducts where possible to minimise disruption and ease of maintenance, as well as reduce conflict with roots of new or existing street trees.
- D. New utilities should be coordinated to facilitate new street tree planting and not be used as a reason to avoid their inclusion.



Figure 33 An example of on street servicing to plots without compromising quality of place



Figure 34 An example of retaining vehicular access and for servicing and emergency use without compromising quality of place

# Nature and Green Infrastructure

## Expected Design Outcome:

A 'green' town centre that maximises the potential for health and wellbeing, biodiversity and climate resilience through the design of new and improvements of existing green infrastructure.

E. Opportunities for play, recreation and exercise should be incorporated where possible. Consider formal, informal, natural, linear, inclusive and accessible spaces and features that support these principles.

## Green Infrastructure

### N01 Green Infrastructure

- A. All planning applications for new development should demonstrate how they respect and enhance the town centre's green infrastructure, positively responding to Key Characteristic 4 'A Green Town Centre', supporting the delivery of new green spaces, whether on plot or beyond and increase access to nature.
- B. Proposed new open spaces should demonstrate how they respond to Key Characteristic 5 'A network of public spaces' through their design and implementation.
- C. All open space that interfaces with the river should demonstrate how it responds to Key Characteristic 2 'Relationship to the River Severn', promoting a positive relationship with the river through its design and implementation and accord with the principles set out in the latest River Severn Shrewsbury Safety Review.
- D. Green Infrastructure proposals should align with Natural England's 15 Green Infrastructure principles and relevant priorities and measures in the Shropshire Green Infrastructure Strategy and Nature Recovery Strategy. Relevant wider stakeholder initiatives and community consultation should also be considered.



Figure 35 The Quarry contributes to the 'Green' town character.



Figure 36 Open space that interfaces with the river should be designed to promote a positive relationship with the water's edge.

#### F. New and adapted open spaces should:

- i. Be accessible and inclusive.
- ii. Be well lit for safety and security but avoid light spillage that causes nuisance and harms wildlife.
- iii. Be located so that they are overlooked by surrounding buildings, streets and public spaces.
- iv. Offer places to sit at appropriate intervals to aid inclusive access along their length.
- v. Consider the opportunity of community growing projects for food production, learning and community engagement on large developments.
- vi. Provide access points and paths that are conveniently located on desire lines for walking and cycling.
- vii. Consider opportunities to incorporate play. Sufficient space should be provided to avoid conflict with other uses.
- viii. Be designed to take account of maintenance and adoption requirements.
- ix. Include areas that are nature-rich to support local biodiversity.



Figure 37 High quality seating within landscape.

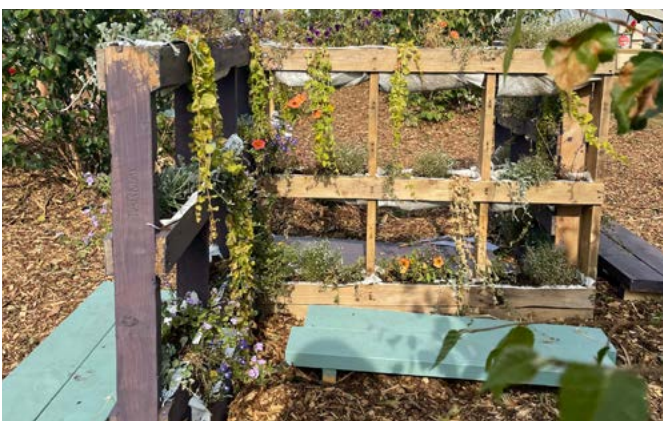

Figure 38 Community growing project.

#### G. Green Infrastructure should be central to the design of the proposals, ensuring permeability of the site for wildlife and people and creating a varied multi-functional network of spaces and uses.

- i. Ensure the design and maintenance of green infrastructure shall conserve and enhance the historic environment and contribute to local distinctiveness.
- ii. GI must be informed by existing features on site or wider networks. Avoid loss, fragmentation, severance, or other negative impact on the function of existing Green Infrastructure. Provide appropriate mitigation if required.
- iii. Incorporate sustainable drainage and blue infrastructure wherever possible.
- iv. Be resilient to climate change, minimise the development's environmental impact and enhance the quality of water, soil and air, aiding resilience, and adaptation to climate change.
- v. Address identified deficiencies and gaps in Green Infrastructure, improving accessibility and encouraging multiple uses where appropriate
- vi. Be accessible and inclusive for all, and promote health, wellbeing, community and cohesion and active living.
- vii. Nature based solutions should be prioritised when dealing with increasing temperatures, to reduce its impact for people's living environments.
- viii. Where nature-based solutions are integrated into the development, it is important to educate and raise awareness of their importance and inclusion to the public. This can begin at public consultation and be sustained after delivery.

## Roofs and Walls

Green walls and roofs support local biodiversity, improve local ecology by creating new wildlife habitats, provide important microclimates for pollinating insects and bird life, and reduce surface water runoff from developments.

### **N02 Roofs and walls**

- A. Green and brown roofs and green walls should be considered in all proposals for new development to demonstrate an improved Urban Greening Factor and maximise opportunities for biodiversity net gain.
- B. State funded and infrastructure buildings should prioritise Brown Roofs for any proposed flat or shallow pitched roof structure to enhance bare earth habitats in the town, or else clearly demonstrate with sound reasoning why green roofs are more suitable. Factors to consider include visibility, maintenance and additional structural requirements.
- C. Green roofs should have due regard to guidance set out in N04 related to SuDS.
- D. Green roofs allow for urban greening, Green Infrastructure connectivity and habitat creation or mitigation of lost habitat. Providing opportunity for bare ground, heathland, meadows / grassland and scrubland in urban areas. They also provide potential opportunities for education and doorstep access to nature.

## Trees

Applications for new buildings or spaces are expected to consider the use of trees within their development through careful consideration of street trees (noting standards within M.1 and M.3), associated public realm and/or within a courtyard.

Tree planting should always follow the maxim of 'the right species of tree, planted in the right way, in the right place, for the right reasons'.

### **N03 Trees**

- A. All aspects of planning, designing, purchasing and implementing tree and hedge planting schemes should accord with the guidance and recommendations of British Standard 8545: 2014 'Trees – From Nursery to Independence in the Landscape'.
- B. Tree species that complement and enhance the ecological value of the local area should be selected.
- C. Suitable tree species should be selected for planting near to car parking spaces, avoiding for example those that have soft berries or a tendency to develop strong surface roots or suckers.
- D. Appropriate sizing, design, and placement of trees within the open space or public realm should be considered, prioritising native species where suitable, recognising that non-native species may be preferable on occasion, for reasons such as their appearance, growth characteristics or resilience to climate change, for example.
- E. New tree planting should provide a mix of species that are resilient to pests, diseases and climate change and should be delivered in sustainable locations, in a manner

that supports the growth and spatial requirements of the canopy which should aspire to a minimum tree canopy cover of 20%. New canopy should positively contribute to the climate resilience of the site in a manner which protects and enhances existing canopy.

- F. The shape, colour, texture and seasonal variations of the trees will have a strong impact on the amenity value. However, aesthetic considerations should not override other important criteria for long-term success when selecting tree species for ecological benefits.
- G. Planting formation choices should reflect local setting, for example a linear arrangement will support a strong urban frontage while individual accent planting might be more suited to public spaces.
- H. Proposed tree locations and specification should be designed with maintenance and adoption in mind for trees in public open spaces.
- I. Lighter canopy trees should be considered when planting closer to buildings.
- i. Street trees in Enhanced and Informal Streets should be planted with a minimum of 1m and maximum 2m setback from kerb lines, and in Pedestrian Priority Streets with a minimum of 1m and maximum 1.5m setback from kerb lines.
  - ii. Spacing of street trees should be between a minimum of 8m and a maximum of 20m apart.
  - iii. A 3m canopy clearance is required for street trees along emergency and refuse vehicle access routes, all other trees require a minimum canopy clearance of 2.5m.
- J. If appropriate within the urban setting consideration should be given to the use of hedgerows too.

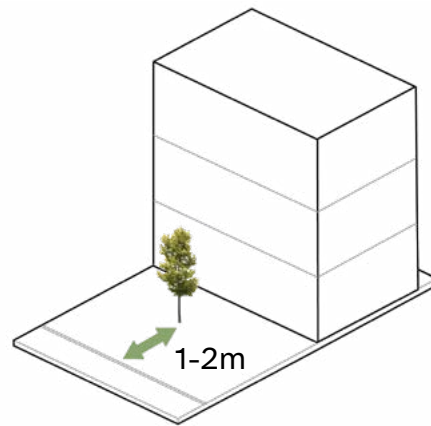

Figure 39 Street trees setback from kerb line.

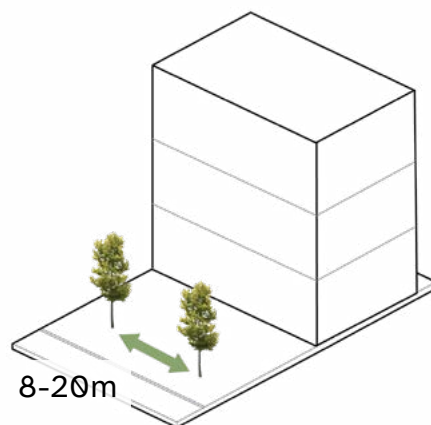

Figure 40 Spacing of street trees.

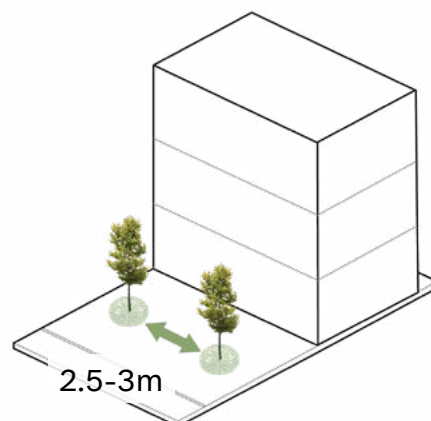

Figure 41 Tree canopy clearance.

# Water and Drainage

## Sustainable Drainage

Sustainable drainage systems (SuDS) are important to deliver the Vision for Shrewsbury town centre, tackling climate change and designing for future generations.

It is vital to remove / reduce the overall level of flood risk in Shrewsbury. Well considered and varied SuDS should be incorporated into all new development to: manage surface water flow, improve water quality, and educate and improve the wellbeing of communities. SuDS should:

- Support the character of Shrewsbury and enhance sense of place, amenity and biodiversity.
- Be planned to ensure they are suitable and appropriate to the historic environment, ensuring in particular that an archaeological interest on the site is fully assessed and appropriate mitigation measures applied.
- Where appropriate, incorporate play features into aspects of SuDS features.
- Provide for simple and straightforward maintenance, including the provision of a plan and mechanism for on-going maintenance.
- Integrate into public, green or open space and have sufficient room.
- When soft SuDS cannot be achieved, use permeable hard surfaces.



Figure 42 Sustainable Urban Drainage including rain gardens, within the design of public realm.



Figure 43 Sustainable Urban Drainage including rain gardens, within the design of public realm.

### N04 Sustainable Drainage

- A. Sustainable drainage systems should be considered to reduce run off rates from new development, mitigate flood risk and enhance biodiversity.
- B. Systems applicable to Shrewsbury town centre include:
  - i. **Green roofs and walls:** Provide capacity to hold and attenuate water run-off as well as ecological and leisure benefits.
  - ii. **Permeable surfacing:** Surfaces that allow water to percolate into the ground including, natural surfaces, gravel and low traffic volume engineered road surfaces and hard-standings.
  - iii. **Rain gardens:** Planters and ditches with native drought tolerant plants release water gradually and filter-out pollutants.
  - iv. **Rain capture:** Water butts and other rainwater harvesting systems collect rainwater for use in gardens or for non-potable uses reducing water consumption.
  - v. **Soakaways and filter drains:** Shallow ditches and trenches filled with gravel or stones that collect uncontaminated water and allow it to percolate into the ground.
  - vi. **Swales and Permeable tree pits**

# Biodiversity

## N05 Biodiversity

- A. Natural assets such as existing trees should, where possible, be retained and enhanced. If their loss is necessary and appropriate then compensatory provision should be made.
- B. Before any new development takes place the existing habitats should be mapped, so that they can, where possible, be retained or otherwise re-provided.



Figure 44 Integrating insect homes and bee bricks, provides features to facilitate increasing biodiversity.

C. Development should consider the following:

- i. **Planting:** To provide nectar, nuts, seeds, native vegetation and berries along with trees and shrubs, logs and stones.
- ii. **Creating habitats:** Strategies need to be considered for creating natural habitats, for example, through use of trees, wildflowers and ponds as well as bat and bird boxes, bee bricks and bird bricks and hedgehog highways.
- iii. **Enhancing habitats:** Management of native planting, foraging grounds for bats, feeding grounds and wetlands for birds and forest floor habitats.
- iv. **Existing features:** Natural assets such as trees and rivers edges should be retained and enhanced where possible.
- v. **Rivers:** Restoration techniques create habitat and reduce flood risk.
- vi. **Mosaics:** A range of elements and structures such as small patches of bare ground, tall flower-rich vegetation, or scattered trees and scrub to support a range of species and their life-cycles. Mosaic habitats can be facilitated by green roofs in an urban context.
- vii. **Trees:** Incorporated into public realm and other open spaces as well as private development where appropriate.
- viii. **SuDS and rain gardens:** Designed to provide benefits to nature by including planting and habitat niches.
- ix. **Ecological network:** Masterplans should create an interconnected ecological network that encompasses everything from doorstep spaces and private gardens to the surrounding countryside.
- x. **Green roofs & walls:** Green façades provide nesting opportunities and food for bees. Habitats can also be created on roofs and are especially beneficial for birds and insects.

# Built Form

## Expected Design Outcome:

A town centre that has a coherent form to which new development appropriately responds.

Built form is defined as the ‘three dimensional pattern or arrangement of development blocks, streets, buildings and open spaces’ that make up an area.

Well designed places have a coherent built form and reflect the prevailing character of its context. For Shrewsbury town centre this means:

1. Developing to an appropriate density that reflects the town centre context and the identified key characteristics.

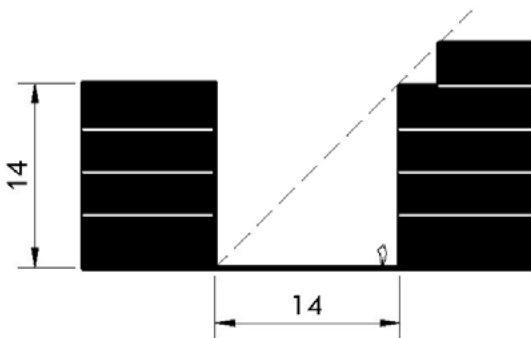

Figure 45 Building height to street width ratio 1:1.

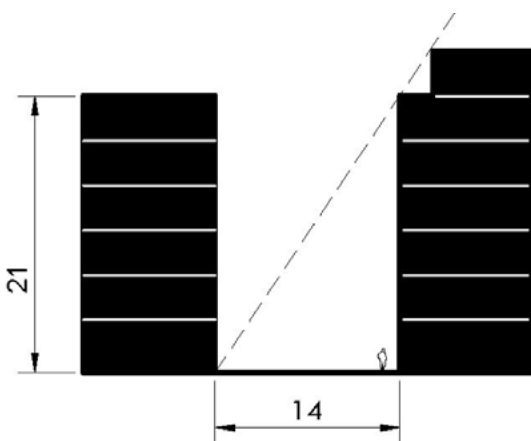

Figure 46 Building height to street width ratio 1.5:1.

2. The layout of plots and sites based on the surrounding street pattern to emphasise the historic urban grain.
3. Use of appropriate building types and forms.

## Scale

### B01 Scale

- A. Proposals for new development should be at an appropriate scale and density in relation to their immediate context and that of the wider town centre.
- B. Proposals should be cognisant of national and local policy requirements aimed at increasing densities at sites proximate to public transport links, services and facilities.
- C. Higher-density schemes should be of notably high quality, meeting the other principles in this guidance.
- D. Proposals should demonstrate how they reflect Shrewsbury Key Characteristic 6 ‘Human Scale’. The scale of a building should have full consideration to the character of the street upon which it is located. Generally, the height of a building should be no more than 1.5 x the width of the street it faces onto (see diagram adjacent).
- E. Scale can be used to define key corners and/or entrances. However the scale should be responsive to surrounding context.
- F. Designers should fully consider the impacts of wind and daylight when considering the scale and the most appropriate location for larger scale buildings within a scheme; ensuring south facing façades, streets and spaces have good daylight access. Use of landscaping to support the absorption of larger scale buildings into their setting is encouraged.

# Massing

## Variety

### B02 Variety

- A. Proposals for new development should demonstrate how they reflect Shrewsbury Key Characteristic 8 'Variety' in relation to:
  - i. Building massing
  - ii. Roof form
- B. Variety in built form can be achieved through subtle changes in height, roof line and typology. However, to avoid too great a contrast, should be balanced by consistency of other aspects such as materials, width of built frontage, angle of roof pitch and fascia height.
- C. Infill development proposals must demonstrate how their design responds to neighbouring buildings in terms of material use and pattern, roof line, scale and set back.
- D. Where larger floor plates are proposed, their form, mass and scale should still achieve variety in roof form, architectural detail and verticality as set out in the Code's key characteristics.

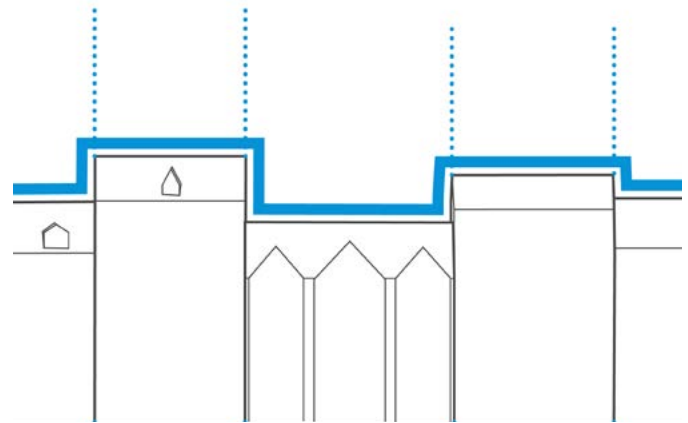

Figure 47 Variety Key Characteristic expressed in building massing.

## Tall Buildings

Tall buildings in the context of Shrewsbury town centre are defined as a building more than 6 storeys in height to the ridge line.

### B03 Tall buildings

- A. Tall buildings should not compromise quality in terms of daylight, overshadowing or overbearance.
- B. The street width to building height ratio should generally be no more than 1:1.5.
- C. The location of tall buildings should be carefully considered to ensure key views are respected.

## Responding to Topography

### B04 Responding to topography

- A. Where relevant, proposals for new development should clearly demonstrate how they reflect Shrewsbury Key Characteristic 1 'Landform and Topography'.
- B. Building form and massing should respond to site topography, stepping up or down in height to reflect changes in level.
- C. Long uniform ridge/eaves lines should be avoided.

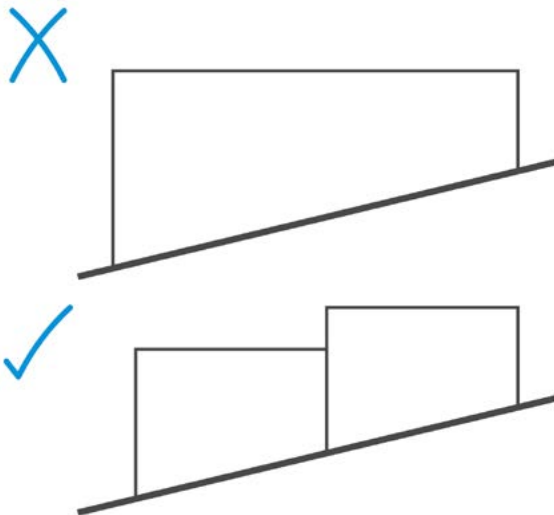

Figure 48 Step architectural form to address steep topography instead of large expansive form.



Figure 49 Claremont Bank - architectural form steps down the street.

## Urban Grain and Block Articulation

### B05 Urban grain and block articulation

- A. All new development should respond to the urban grain of the town centre, as set out in Key Characteristic 3 'Fine Urban Grain', framing an intricate network of streets and spaces.
- B. Where new development blocks are created, proposals should demonstrate how a permeable perimeter is created, which is well defined and has activated pedestrian and vehicular corridors, with clear definition between public and private spaces.
- C. New development blocks should have a continuous built edge with buildings or appropriate boundary treatment. Gaps in the perimeter can be accepted if they do not compromise the integrity of the block.
- D. Large new urban blocks should introduce additional public streets to increase permeability.
- E. Blocks should be subdivided into smaller buildings or the external appearance of larger buildings should be articulated to break up the massing and alleviate uniformity.
- F. Massing of individual buildings within a new block should vary to provide variety to the streetscene.
- G. Roof form should provide variety and respond to the site's town centre context.

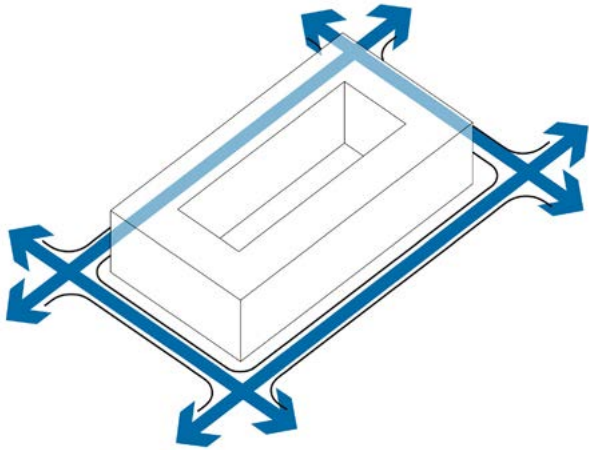

Figure 50 B. Perimeter Block defined by movement corridors.

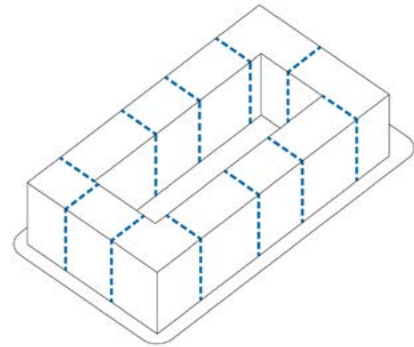

Figure 53 E. Blocks should be sub-divided into buildings.

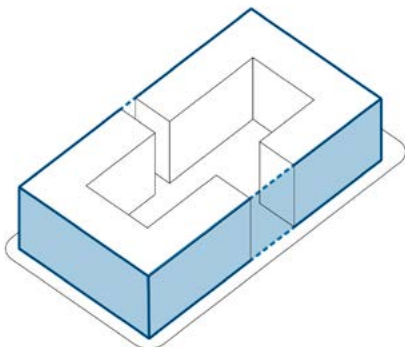

Figure 51 C. Continuous built edge, with gaps accepted if they do not compromise the integrity of the block.

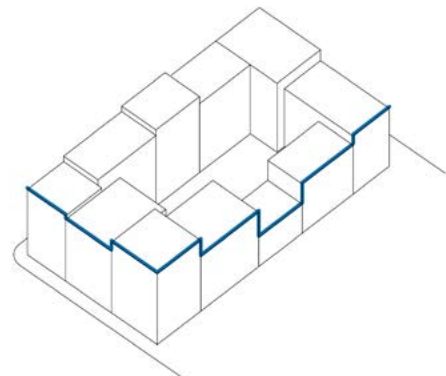

Figure 54 F. Varying massing and roof heights to provide variety.

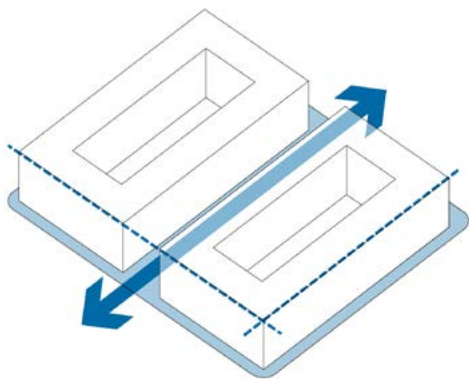

Figure 52 D. Large block should have additional movement corridors to increase permeability.

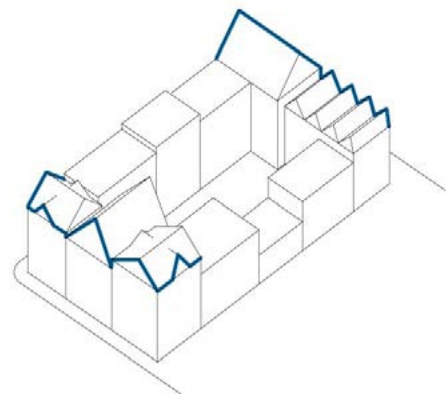

Figure 55 G. Roof form should provide variety and respond to local context.

# Identity

## Outcome:

A place that contributes to and enhances the positive character of Shrewsbury town centre. A place that feels distinctively local, new development responding to local building composition, roof form, materials and details in a sensitive contemporary way.

## Sense of Place

### Local Character

#### I01 Local Character

- A. Any new development within Shrewsbury town centre should be sensitive to its context and proposals should clearly evidence how they respond to the Shrewsbury Key Characteristics which define local character.
- B. Interpretation must positively respond to the character, appearance and historic interest of the town centre through traditional or contemporary design but avoid simple duplication or imitation.
- C. Landscape features can support Shrewsbury's identity. Shrewsbury is the town of flowers and increasing flowering species supports this and the principle of the 'Green Town'.
- D. Play spaces and playful features in the public realm can support local identity by referencing local history or landmarks and, or responding to the topography of Shrewsbury.

## The Identity of Buildings

### Composition & Building Articulation

#### I02 Composition and building articulation

- A. The proposed composition should demonstrate how Key Characteristic 11 'Definition of the Base, Middle and Top' will be addressed whilst maintaining an overall synergy and ensuring the building is read as one. This could be achieved by:
  - i. Architectural form
  - ii. Change in materials and/or
  - iii. Change in architectural detailing or expression



Figure 56 A contemporary building with a clearly defined composition of base, middle and top.

- B. The location of fenestration (windows and doors) and its rhythm should be regular and demonstrate an appropriate response to neighbouring buildings. Long glazed elevations or large blank façades should be avoided.
- C. Building composition should emphasise vertical orientation, consistent with Shrewsbury Key Characteristic 9 'Verticality', through form, fenestration and architectural details, dividing the elevation into vertical segments to create a vertical rhythm.
- D. Designers should consider strategies such as subtle colour/ material contrast, minor wall offsets, the use of arcades, accent lines and upper floor step backs to articulate buildings. The uppermost portion of the façade should be articulated with a treatment in scale with the building.



Figure 57 Verticality Within Buildings: Elevations divided into vertical segments to create a vertical rhythm.

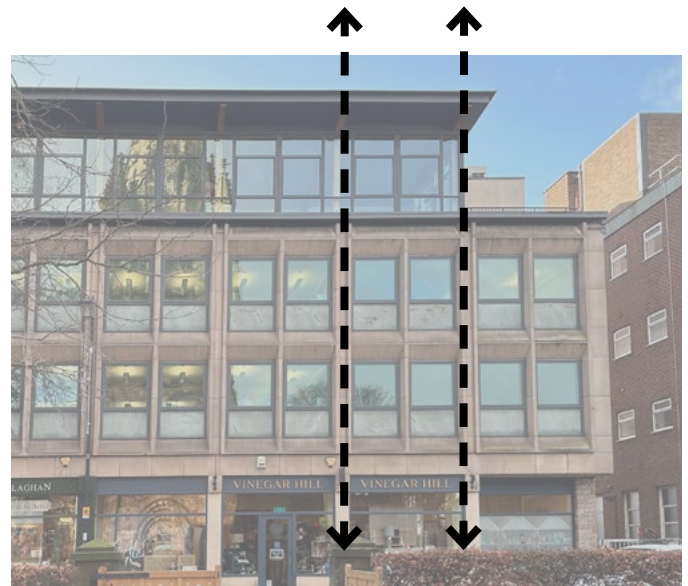

Figure 59 Expressing verticality - 22-24 St Mary's Street: A bay typology can introduce verticality to break up a horizontal elevation.

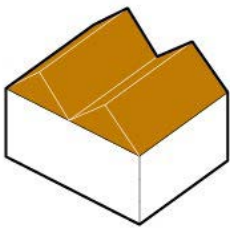

Figure 58 A regular use of fenestration creating rhythm.

## Roof form

### I03 Roof form

- A. Proposals for new development should clearly demonstrate how they reflect Shrewsbury Key Characteristics 8 and 10, 'Variety and Contrast' and 'Varied Roofscape'.
- B. Continuous repetition of roof forms and long uniform ridge lines should be avoided.
- C. Roof articulation and set backs should be considered on upper stories to reduce the impact of massing or height.
- D. Buildings should have an uncluttered simple roof profile with all elements such as plant enclosure, solar PVs, maintenance gantries, lift overruns, safety balustrades etc. integrated within the overall built form and set back from the roof edge.
- E. Roof form should respond to the existing context and feature pitch or mansard roofs, to the street. Whilst a top floor set back may be featured, the use of flat roofs should be avoided where the predominant roof form in the surrounding area is pitched and limited to roof gardens and balconies away from main facades.
- F. Dormers should be carefully integrated into the roof line facing onto the street, being careful to maintain symmetry.
- G. Gables facing onto the street should be considered to articulate corners and break long roof lines.



Type 1: Pitched roof.

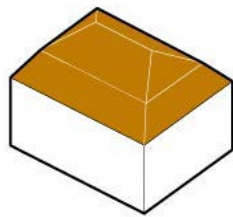

Type 2: Mansard roof.

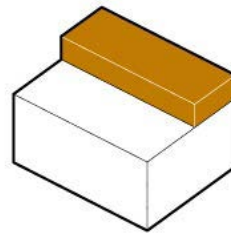

Type 3: Top floor set back.

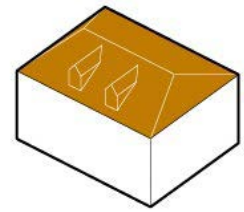

Type 4: Roof with dormers.

Figure 60 Typical roof forms

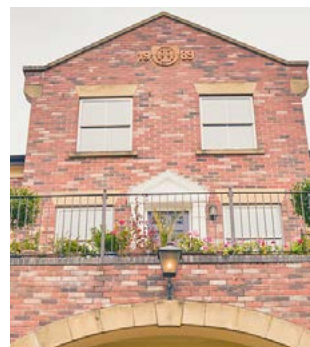

Figure 61 Examples of Shrewsbury roof forms.

## Materials and Details

### IO4 Materials and details

- A. Proposals for new development should take inspiration from a local palette of materials (refer to materials palette in this document) Where this is not the case, they should justify sympathetic use of other materials.
- B. Proposals should take inspiration from the palette of patterns, colours and iconography of Shrewsbury town centre, referencing where appropriate Key Characteristic 12 'Intricate patterning and detailing'.
- C. Signage and any associated lighting or fascias, should be simple, integrated and contextually appropriate. It should also positively contribute to the streetscape, utilising a consistent and complementary style.
- D. Shopping fascia's should be of a consistent height and depth throughout the town centre, whilst also reflecting changes in level.
- E. Key frontages, and larger areas where blank façades are unavoidable, should use brick details and patterning, including colour contrast, to provide interest.



Figure 62 Window frame materials complement the external material of a development.

## Windows

### IO5 Windows

- A. Window frames must complement the external material of the new development and respond to surrounding character.
- B. New development should consider the use of surface reliefs and depth of shadows to avoid creating flat façades. The use of deep reveals is encouraged to emphasise building details, such as grids, and offer solar shading.



Figure 63 Image of contemporary buildings in Shrewsbury using local palette of materials. Radbrook Village, Shrewsbury. Photo credit AHR Architects.

# Public Space

## Expected Design Outcome:

A town centre where the public spaces are well designed, robust, inclusive and safe.

Public realm is the space between buildings that is publicly accessible to everyone as defined by the Shrewsbury Movement and Public Space Strategy as public space. The use of the phrases public space and public realm are often interchangeable, but the definition remains the same.

Whilst streets are dealt with in section M1 of this document, N1 Nature also sets out coding for green infrastructure. This section sets out further principles for the design of the public realm within and around development proposals.

## Public Realm

### P01 Public realm

- A. A refined palette of street furniture and paving should be used, selected for longevity, ease of maintenance, and quality. It should create further cohesion in the space and encourage people to dwell and socialise.
- B. Consideration should be given to designing for inclusive spaces, such as curved seating to encourage social interaction and safety.
- C. Street furniture and public art should be used to reinforce the character and identity of the area but in a way that limits street clutter, and rationalises signage.
- D. All street furniture should be robust and easy to maintain and replace.
- E. All new lighting should be robust, fit for purpose, easily replaced, and energy efficient (with a preference for LED lighting).
- F. Planting should be distinctive, providing visual interest and intrigue.

- G. Consideration should be given to need for public spaces to be designed to be inclusive and accessible for all users.
  - i. Seating to leave space for wheelchairs, mobility scooters or pushchairs to sit alongside without blocking circulation.
  - ii. A range of scale in seating spaces – quiet corners, busier areas, to give people the option.
  - iii. Avoid steps and include ramps.
  - iv. Designing spaces for neurodiversity.
  - v. Consider the principles of gender inclusive design – alternative seating areas like groups of swings or hammocks that allow older children to hang out without feeling they are impeding on children’s play areas.
  - vi. Linear play features / pocket play on the high street to entertain children with a parent waiting for someone to finish shopping. For example, trampolines, slides incorporated with level changes by steps and ramps.
  - vii. It is important for outdoor spaces to have the ability to accommodate programmed and non-programmed use (multifunctionality).
  - viii. Good open space should allow a variety of uses along the themes of; sit, rest, socialise, play, exercise, eat, drink. The uses should depend on the context of the development.
  - ix. Open space should be as green as possible and include SuDS, provide visual amenity, and be connected to existing pedestrian and cycle networks.
- H. Features such as bins, cycle stands, and seating opportunities must be included but in a considered way that minimises unnecessary clutter.



Figure 64 A refined palette of street furniture should be used for longevity and quality.

- vi. Public spaces should deter criminal activity through their design. However sometimes it is necessary to also include additional security features. These should be well designed and integrated into the space.
- vii. Public spaces should be designed with management and maintenance in mind, with stewardship established, to discourage crime in the present and the future and promote longevity of the space.

## Safety and Security

### P02 Safety and security

- A. All public space should be designed to adhere to the following safety and security principles:
  - i. Routes should be designed with integrated CCTV in mind, promote wide, well lit and direct connections, support ease of maintenance, and benefit from natural surveillance that provides a sense of security for all users and discourage anti-social behaviour.
  - ii. Access points should be designed to have good visibility and allow open views to encourage use by all.
  - iii. There should be clear separation between public and private spaces.
  - iv. All spaces that are publicly accessible should benefit from natural surveillance from active frontages on surrounding buildings.
  - v. Public spaces should be designed to promote a sense of ownership, respect, responsibility and community.



Figure 65 Low level planting and clear sight lines increase visibility and comfort.



Figure 66 Use of low level lighting and accent lighting to planting will encourage use and safety throughout the day.

# Play

## P03 Play

- A. Opportunities for play should be incorporated into new development within Shrewsbury town centre, as it is a vital resource. Play needs to consider all people, ages, abilities, and needs.
- B. Play can be delivered in several ways depending on the context:
  - Play Areas
  - Play on the way
  - Playful interventions
  - Interactive art
  - Play streets
  - Natural Play
  - Provision for Exercise and Fitness
  - Provision of equipment in open space to facilitate play/ games.
  - Child orientated play
  - All age , games exercise, health and wellbeing.
- C. Play Areas should:
  - i. Support Children’s Fundamental Movement Skills and provide risk and progression of challenge.
  - ii. Avoid non-specific, bland and repetitive play experiences. New play spaces should consider existing provision and deliver something different. There may be opportunities to think, about sensory play, or digital / interactive features.
  - iii. Be inclusive and accessible within the main play experience to avoid any sense of separation.
  - iv. Be well located on busy routes, benefit from natural surveillance, and used to enhance community spaces.

- D. Fitness and Exercise spaces should:
  - i. Be well located and used to enhance community space.
  - ii. Allow for a range of users and abilities and avoid one user group dominating the space. Provision should include instructions on how to use the features. Where fitness equipment is included, include opportunities for a range of stretching, upper and lower body exercise (whether on a single location or part of a trail).
  - iii. Dynamic moving units or static units that allow users to bring resistance bands are both appropriate.
  - iv. Consider inclusion of running lanes or distance markers along paths.



Figure 67 An example of play on the way.  
Credit: Neil Speakman/Studio Maple

# Hostile Vehicle Mitigation

Hostile Vehicle Mitigation (HVM) measures keep everyone safe and can be used to prevent criminal damage and harm to people or buildings. Martyn's Law, officially known as the Terrorism (Protection of Premises) Act 2025, aims to enhance public safety by requiring certain venues and events to implement measures to protect against terrorist attacks.

## P04 HVM

- A. Any new public space with potential to host events must comply with the tiered approach based on the anticipated venue capacity.
- B. HVM measures should be integrated into the holistic design of a street or space.
- C. HVM measures should be proportionate to the perceived threat to avoid unnecessary street clutter in the public realm.
- D. Passive measures such as incidental street elements, sculptures, water, play space, walls, bunds, ditches, topography, raised planters and street furniture are preferred.
- E. Extensive use of bollards should be avoided wherever possible and any requirement for access should be managed carefully to ensure flow of vehicular and pedestrian traffic.
- F. Applicants considering new development should engage early with the Local Authority to ensure HVM is fully integrated into the design proposal.



Figure 68 HVM integrated into the design of the public realm.

# Uses

## Expected Design Outcome:

A town centre where a vibrant mix of uses support everyday activities and bring life, activity, and bustling streets. A place that works for commercial, residential, culture and communities.

## Mix

### U01 Mix

- A. Proposed new development should be consistent with policies in the adopted Development Plan. They should also respond to the adjacent and town-wide offer to ensure they complement rather than compete.

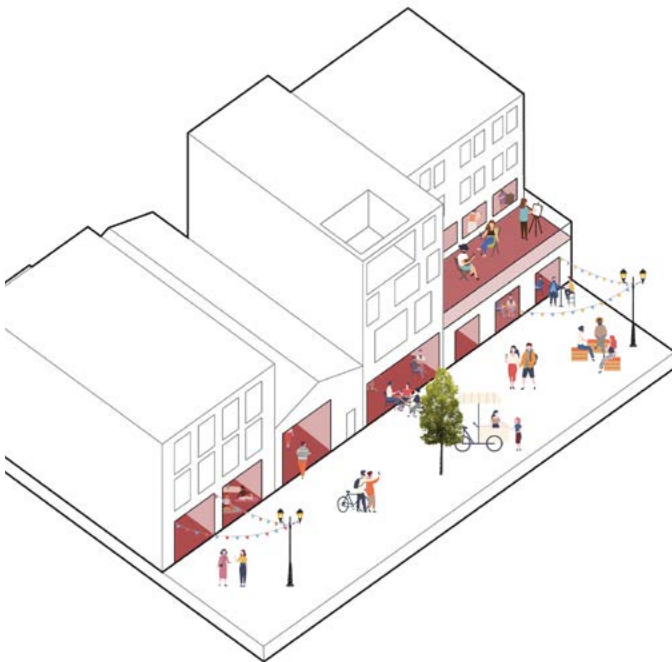

Figure 69 Building frontage activated on ground floor and on terrace to encourage activity on the street and increase surveillance.

## Active Frontages

### U02 Active frontages

- A. New buildings should have active frontages onto streets and other public realm. This should include glazing and/or other openings so as to provide natural surveillance and to allow activity in the building to be clearly visible.
- B. Where new buildings are for commercial uses, active commercial terraces can create diversity and increase footfall. As such, they are encouraged where they can be appropriately accommodated in the building design and appropriately respond to its setting.
- C. Spill out space onto the street is encouraged where it can be clearly defined and comfortably accommodated without unduly compromising other uses.
- D. Where active frontages at street level are not possible due to an associated environmental assessment and heightened risk of flooding, an alternative approach is required to demonstrate activity within the buildings is visible.



Figure 70 Historic and modern active frontages encouraging street activity.

# Homes

## Expected Design Outcome:

A town centre that accommodates a mix of building, for all ages, which is proud of the high design standard of all new residential buildings, which are of exemplar quality in terms of functionality, accessibility, inclusivity and sustainability.

## Residential Quality

### H01 Residential quality

- A. All dwellings should achieve high-quality sustainable design, which is adaptable, safe and accessible to all and is responsive to changing lifestyle needs. This includes achieving the M4(2) accessible and adaptable standard as a minimum, and for schemes of 5 or more dwellings a minimum of 5% achieving M4(3) wheelchair user dwelling standard (unless site-specific factors indicate that step-free access cannot be achieved).
- B. Proposals should include an appropriate and diverse mix of dwelling types, sizes and tenures that respond to local need. They should be distributed through the site.
- C. Design should maximise dual or triple aspect dwellings and limit the number of single aspect dwellings – particularly those that are north-facing. Exceptionally, where such units are appropriate, they should not constitute family housing
- D. Building design should seek to maximise daylight penetration. As such, depth should not exceed 7metres except for units with recessed balconies.
- E. In duplex apartments, opportunities to face kitchen and living towards streets and public spaces/courtyards should be prioritised.



Figure 71 Buildings should maximise daylight within homes.

- F. Building design should promote natural surveillance of adjoining public spaces. It should also encourage community interaction, engagement, participation and passive environmental control.
- G. Apartments and maisonettes should, wherever possible, include private amenity space that is clearly associated with and accessible from the property. In some instances, it may be acceptable for this to consist of a balcony - dependent on factors such as potential for alternative provision, size, and whether they complement the design of the building and its locality. Where this is the case, it should be complemented by appropriate communal space.
- H. Where the buildings are orientated north/south, they should be designed with a reduced number of units per core to maximise dual aspect units and avoid north facing single aspect units.
- I. Cores should be located at the perimeter of the blocks so they, and associated circulation spaces, receive natural light and ventilation.
- J. The number of dwellings per storey of a core should not exceed 8 to encourage neighbourly interaction and occupier ownership.

## Gardens and Balconies

### HO2 Gardens and balconies

- A. Private amenity space should ideally be designed to be accessible from the living-room and/or kitchen.
- B. Where balconies are considered appropriate (complement the design of the building, its locality, and satisfy amenity considerations) they can project outwards up to 2 metres beyond the building frontage (but not beyond the development plot boundary) subject to maintaining minimum balcony to balcony facing distances of 18 metres.
- C. Balcony design options include those which project, are recessed or are semi recessed. Their forms should be fully integrated into the architectural composition of the façade, complement the character of the area and achieve satisfactory amenity standards.
- D. Adjoining balconies should be designed with appropriate screenings to achieve a level of privacy.



Figure 72 Balconies can project up to 2m and should be fully integrated in the design of the building.

## Detailing

### HO3 Detailing

- A. Attention to detailing is important in achieving the desired quality of the development and giving the development a human scale (Key Characteristic 6). Special attention should be focused in areas where people come into direct contact with buildings such as entrances and at ground level.
- B. Maintenance access and cleaning equipment should be discretely designed and integrated into the building and façade detailing avoiding areas that may be visible from the street.
- C. Utility boxes and meters should be hidden or integrated within entrances to houses and apartments while remaining accessible to utility company staff.
- D. Collection of waste and recycling should be carefully considered during the design of the buildings and streets.
- E. The provision of projecting canopies on buildings maybe allowed up to a distance of 2.5metres, where they complement the design of the building, its locality, and satisfy amenity considerations. Canopies should be integrated into the architecture of the building and should not obstruct the width of the road or footpath nor compromise the integrity of the public realm.

# Resources

## Expected Design Outcome:

A town centre where new development is exemplar - sustainable design of buildings, efficient use of water and, energy, and local materials

## Energy

### Passive Design and Orientation

#### R01 Passive design and orientation

- A. Proposals for new development should demonstrate how they have considered optimising orientation, massing and shade to minimise overheating.
- B. They should demonstrate how sufficient light penetration has been achieved into all habitable spaces, and maximise dual aspect units where possible.



Figure 73 Orientating roofs to incorporate PVs. Radbrook Village, Shrewsbury. Photo credit AHR Architects.

### Solar Energy Generation

#### R02 Solar energy generation

- A. Proposals for new development should demonstrate how they have considered the opportunities for solar photovoltaics (PVs) and other forms of low or zero carbon technology whilst also considering the overall design and skyline.

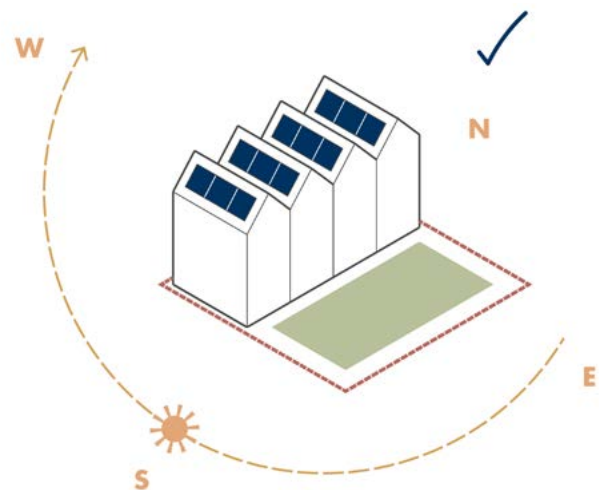

Figure 74 Strategic Design: Orienting blocks to avoid excessive solar gain along long elevations and articulating a roof to allow for the use of PVs.

# Sustainable Construction

## Windows, shading and cooling

### RO3 Windows, shading and cooling

- A. New developments should incorporate efficient glazing to maximise thermal performance of buildings.
- B. Opportunities for shading (through design or integrated devices) should be considered to reduce the reliance on mechanical ventilation.
- C. Passive design measures to address solar gain, shading and cooling should be carefully considered to reduce energy, heating and light demand in buildings. This should be achieved through consideration of massing and building orientation first, then through integrated architectural elements (reveals, projections etc.)
- D. Shading features should be well integrated into the architectural composition of new buildings.

## Environmental Standards

### RO4 Environmental standards

- A. New developments should use a certified structure such as the 'One Planet Framework', 'LETI' or other equivalent to ensure sustainability is prioritised and addressed in all areas of development.
- B. They should strive to gain certification from an accredited sustainability assessment such as BREEAM, LEED, WELL, SKA or equivalent.

## Retrofitting

### RO5 Retrofitting

- A. To minimise carbon footprint and other impacts, opportunities to refurbish or convert existing buildings should be explored before it is determined that redevelopment is the preferred approach.
- B. If the building is listed or within the town centre conservation area take heritage-appropriate retrofit guidance in support of your planning application.
- C. When refurbishing or converting buildings, consideration should be given to opportunities to enhance energy and water efficiency and integrate low and zero carbon energy generation and EV charging.
- D. If demolition is required, re-use of materials should be maximised.
- E. New residential developments should be designed to be safe and accessible to all and responsive to changing lifestyle needs including mobility.



Figure 75 Efficient glazing should be considered to maximise thermal performance.

## Embodied Energy

### R06 Embodied energy

- A. New development should employ a 'Fabric First' approach to reduce the reliance on technological solutions towards thermal performance.
- B. Sustainable sourcing and carbon footprint should be priorities when selecting materials.
- C. New developments should utilise benchmarked data to ensure whole life carbon emissions are minimised.



Figure 76 Developments should explore re-use solutions to minimise carbon footprint.

## Operational/Whole Life Energy

### R07 Operational/whole life energy

- A. New development should maximise energy efficiency, which will contribute significantly towards reducing the whole life carbon footprint.
- B. They should explore zero combustion options for heating.
- C. They should seek to utilise or implement heat sharing networks.
- D. Ground source heat pumps should be considered over air source pumps where possible as they are more efficient, a renewable source of energy and reduce the carbon footprint of buildings.
- E. They should utilise demand-based services where possible.

## Modern Methods of Construction

### R08 Modern methods of construction

- A. New development should strive to utilise modern methods of construction where possible, whilst respecting local character (Key Characteristics 1-12).

## Water Saving

### R09 Water saving

- A. New development should maximise water efficiency measures thereby meeting the optional Building Regulations' 110 litres per person per day standard.
- B. To complement water efficiency measures, new development should also consider implementing systems such as grey water recycling, and rainwater collection and re-use.

# Delivering Design Excellence





The following sets out the key considerations for successfully applying the recommendations in this Design Code.

### **Implementing the Design Code**

This Design Code forms a material consideration for planning applications for new development within Shrewsbury town centre. Applicants are requested to follow the steps outlined within the Code to;

1. Show a full appreciation of the design context;
2. Clearly illustrate how they have followed the town centre and character area codes and how these are reflected in their proposal(s);
3. Outline how the design proposal(s) has adhered to the requirements of this Design Code and complete the Application Check List provided on the following pages. This can be provided separately; and
4. Express clear stages of delivery to assure the Council of their ability to deliver on the aspirations of the application.

As well as a tool for planning decisions, the Design Code will be used to frame pre-application discussions. Applicants proposing new development in the town centre are requested to frame their pre-application submissions around the themes of this Design Code as appropriate.

## Viability

There may be occasions where the principles set out in this Design Code impact upon the viability and deliverability of a development. In such circumstances, in accordance with paragraph 58 of the NPPF, there may be an opportunity for an applicant to justify non-compliance on the individual viability of a scheme, but only when an open book approach to viability appraisal is adopted.

This does not, however, exempt the developer from utilising the appropriate professional inputs or adopting the design process, standards and requirements set out in this Design Code in order to achieve the high quality design outcomes required by the NPPF, adopted Development Plan, National Model Design Code and National Design Guide. As such, developers should seek to deliver creative solutions to match the aspirations of the Design Code with the ultimate delivery of high quality, resilient and sustainable development.

## Post application and conditions

When new development proposals are granted planning permission, the Council will use appropriate conditions to ensure that the design quality of development is achieved.

For outline proposals, the Council will seek to agree certain development “fixes” which may take the form of a development framework or masterplan. In this context,

a condition will require subsequent reserved matters applications to relate to key masterplan design principles and parameter drawings.

For detailed applications, conditions may require further details to ensure a quality outcome on specific aspects, including materials and landscape specifications.

## Value engineering and quality in delivery

Value engineering is important in ensuring appropriate feasibility and best value is achieved for elements of the design proposals. Value engineering, however, should not be a process which compromises the eventual design quality of the outcome. The Council will resist subsequent applications for minor amendments or to vary extant permissions or conditions that are likely to impact on the quality of the architecture or public realm set out at the application stage.

## Engagement through the Planning Process

Meaningful engagement should form part of the design process. Engagement should not be seen as a final hurdle before application, it should instead be seen as a vital tool in the creation of the best possible design outcome.

The developer’s vision and concept plan should allow them to present the basic structure of the proposals, and the thinking behind them, to a range of audiences, including:

1. To improve the efficiency of the planning application process and the quality of proposals you may wish to consider the Council's Pre-Application Advice Service, which can incorporate a Design Review - it is important to engage council planning officers at the outset and at key project milestones throughout any project. These discussions can confirm whether the principle of development is acceptable and provide clarity on the format, type and level of detail required to enable an application to be determined. The pre-application discussions should ultimately lead to a more efficient process and desirable design solution. As outlined, this Design Code should frame these discussions. The approach to Pre-Application engagement can be tailored to the nature of the proposed development and can be supported by officers from appropriate departments, such as policy, highways, heritage and ecology.
2. Community consultation and co-design – applicants will always be encouraged to consider the benefits of involving the community in developing their proposals. Suggested engagement methods include the use of questionnaires and surveys, public exhibitions or meetings, design workshops with community groups and other stakeholders (including access groups), websites and site notices. For larger scale proposals, the Council strongly encourages a two stage public consultation process – both at the concept and more detailed design stages.

The design process will be greatly enhanced through engagement with harder to reach groups, such as less able bodied or ethnic minorities. As such, applicants are encouraged to actively engage with all groups. Further information is available on the Council website:

<https://next.shropshire.gov.uk/planning/applications/pre-application-advice/>

## **Design Review and Social Value**

The design review process is a well established way of improving the quality of the design of development and is advocated by the NPPF and National Design Guide.

The purpose of a Design Review is to assess planning proposals for developments and provide advice and support to promoters and planning officers to help deliver high quality design. It essentially involves reviewing scheme proposals with an independent, multidisciplinary panel of built environment experts. Schemes can be reviewed at all stages of the planning application process, although a review at the concept stage often helps to add more value to the design.

Shropshire Council strongly advocates the use of a Design Review as part of the pre-application process.

Whilst reviewing design quality, Shropshire Council will also encourage a review of social value. This should consider the social impact of the development; including skills, learning, job creation, access to amenity, inclusive use and other key indicators which could also include contributions to associated social projects it has in development or delivery. Developers are encouraged to clearly outline the social value of their design.

## **Review of Design Code**

This Design Code document will be periodically reviewed as resources allow.

# Required Information

## LD Æ DESIGN

This Self-Assessment Checklist guides applicants and officers through the requirements of this Design Code. It is intended to be used as a guide to streamline the planning process and as such should be completed and submitted alongside planning applications for new development in Shrewsbury town centre.

Design Code	Applicable	Not Applicable	Complied with	Not Complied With	Please clearly set out in the column below, in which document of your application you have demonstrated compliance. (e.g. Page X of Design and Access Statement) If not complied with, please state why.	Council Confirmation and comments (Applicants Leave Free)
<b>The Design Vision and Understanding Shrewsbury town centre's Character</b> The Design Code sets out a vision for Shrewsbury town centre defines it's key unique characteristics, and identifies expectations for new development in order to positively respond to its unique character and achieve the requirements of the adopted Development Plan. New development should respond to this framework.						
Have you developed a 'Design Vision' and 'Concept Plan' which captures and responds to opportunities and constraints on the site and key relationships in its setting? <i>This 'Design Vision' and 'Concept Plan' should form part of the evidence supporting any planning application.</i>	<input type="checkbox"/>	<input type="checkbox"/>	<input type="checkbox"/>	<input type="checkbox"/>		

# LDĀ DESIGN

Design Code	Applicable	Not Applicable	Complied with	Not Complied With	Please clearly set out in the column below, in which document of your application you have demonstrated compliance. (e.g. Page X of Design and Access Statement) If not complied with, please state why.	Council Confirmation and comments (Applicants Leave Free)
Does your 'Design Vision' and 'Concept Plan' respond to the unique characteristics of Shrewsbury town centre, with reference to the vision and Key Characteristics set out in this Design Code?	<input type="checkbox"/>	<input type="checkbox"/>	<input type="checkbox"/>	<input type="checkbox"/>		
Rooted in heritage - is the 'Design Vision' informed by a professional heritage consultant and does it give specific consideration to heritage?	<input type="checkbox"/>	<input type="checkbox"/>	<input type="checkbox"/>	<input type="checkbox"/>		
Green and blue links - does the 'Design Vision' give specific consideration to green spaces and relationship to the river?						
Has the 'Design Vision' drawn upon meaningful engagement with the public and key stakeholders?	<input type="checkbox"/>	<input type="checkbox"/>	<input type="checkbox"/>	<input type="checkbox"/>		

LDĀ DESIGN

Design Code	Applicable	Not Applicable	Complied with	Not Complied With	Please clearly set out in the column below, in which document of your application you have demonstrated compliance. (e.g. Page X of Design and Access Statement) If not complied with, please state why.	Council Confirmation and comments (Applicants Leave Free)
<i>Engagement processes, responses and outcomes must be outlined in evidence supporting any planning application.</i>						
<b>Movement</b> New development must contribute to an accessible and connected town centre, delivering a public environment that highly supports walking, wheeling and cycling. It must also positively respond to the place-making role of streets.						
<b>M01 Streets</b>						
Using the street typologies defined in this Design Code have you your proposed development adjoins? <i>The typology of streets adjoining a site must be outlined in evidence supporting any planning application.</i>	<input type="checkbox"/>	<input type="checkbox"/>	<input type="checkbox"/>	<input type="checkbox"/>		
For proposals that would result in the creation of new streets or change the	<input type="checkbox"/>	<input type="checkbox"/>	<input type="checkbox"/>	<input type="checkbox"/>		

# LDĀ DESIGN

Design Code	Applicable	Not Applicable	Complied with	Not Complied With	Please clearly set out in the column below, in which document of your application you have demonstrated compliance. (e.g. Page X of Design and Access Statement) If not complied with, please state why.	Council Confirmation and comments (Applicants Leave Free)
<p>character of existing streets such that it changes typology, have you:</p> <ul style="list-style-type: none"> <li>- Considered their place-making and movement needs and opportunities?</li> <li>- Established their street typology within a Street Framework Plan which defines the proposed hierarchy, impacts on existing street layout, and summarises place-making and movement functions?</li> </ul> <p><i>The Street Framework Plan must form part of the evidence supporting any planning application. This should include clearly measured and drawn sections of existing and proposed</i></p>						

LDĀ DESIGN

Design Code	Applicable	Not Applicable	Complied with	Not Complied With	Please clearly set out in the column below, in which document of your application you have demonstrated compliance. (e.g. Page X of Design and Access Statement) If not complied with, please state why.	Council Confirmation and comments (Applicants Leave Free)
<i>street types and highlight any distinctive features to be incorporated into the new scheme.</i>						
For proposals that would not result in the creation of new streets or change the character of existing streets such that it changes typology, have you: - Considered the opportunities that adjoining streets create for the design and layout of development? <i>This consideration should be detailed within the evidence supporting any planning application.</i>	<input type="checkbox"/>	<input type="checkbox"/>	<input type="checkbox"/>	<input type="checkbox"/>		
<b>M02 Active Travel</b>						
Have you prioritised opportunities for active travel, consistent with the	<input type="checkbox"/>	<input type="checkbox"/>	<input type="checkbox"/>	<input type="checkbox"/>		

LDĀ DESIGN

Design Code	Applicable	Not Applicable	Complied with	Not Complied With	Please clearly set out in the column below, in which document of your application you have demonstrated compliance. (e.g. Page X of Design and Access Statement) If not complied with, please state why.	Council Confirmation and comments (Applicants Leave Free)
Shrewsbury Movement Hierarchy in this design code? <i>The approach to prioritising active travel should be detailed within the evidence supporting any planning application.</i>						
<b>M03 Parking</b>						
Where new car parking is proposed, has its design been informed by the options (and their pros and cons) detailed in this Design Code?	<input type="checkbox"/>	<input type="checkbox"/>	<input type="checkbox"/>	<input type="checkbox"/>		
Where new car parking is proposed, is it fully integrated into the design - so to be safe, attractive to use, and carefully located so as to not detract from the appearance of the town centre?						

LDĀ DESIGN

Design Code	Applicable	Not Applicable	Complied with	Not Complied With	Please clearly set out in the column below, in which document of your application you have demonstrated compliance. (e.g. Page X of Design and Access Statement) If not complied with, please state why.	Council Confirmation and comments (Applicants Leave Free)
<i>The approach to any new car parking, should be detailed within the evidence supporting any planning application, supported by illustrative plans and sections.</i>						
Where new servicing is proposed, is it fully integrated into the design - so to be safe, convenient to use, and carefully located so as to not detract from the appearance of the town centre? <i>The approach to any new servicing, should be detailed within the evidence supporting any planning application, supported by illustrative plans and sections.</i>						
<b>Nature</b>						

# LDĀ DESIGN

Design Code	Applicable	Not Applicable	Complied with	Not Complied With	Please clearly set out in the column below, in which document of your application you have demonstrated compliance. (e.g. Page X of Design and Access Statement) If not complied with, please state why.	Council Confirmation and comments (Applicants Leave Free)
New development proposals must integrate green infrastructure to maximise potential for health and wellbeing, biodiversity and climate resilience.						
<b>N01 Green Infrastructure, N02 Green roofs and walls, N03 Trees, N04 Sustainable Drainage, N05 Biodiversity</b>						
With regard to the key characteristics of Shrewsbury, have you considered opportunities for green infrastructure from the outset of design, and maximised opportunities within the site and for connectivity beyond? <i>The strategy for Green Infrastructure, supported by illustrative plans which show on site provision and how these knit into the wider network, should be detailed within the evidence supporting any planning application</i>	<input type="checkbox"/>	<input type="checkbox"/>	<input type="checkbox"/>	<input type="checkbox"/>		
Have you considered sustainable drainage from the outset of design -	<input type="checkbox"/>	<input type="checkbox"/>	<input type="checkbox"/>	<input type="checkbox"/>		

LDĀ DESIGN

Design Code	Applicable	Not Applicable	Complied with	Not Complied With	Please clearly set out in the column below, in which document of your application you have demonstrated compliance. (e.g. Page X of Design and Access Statement) If not complied with, please state why.	Council Confirmation and comments (Applicants Leave Free)
<p>in doing so have you considered opportunities to enhance biodiversity? <i>The approach to sustainable drainage, should be detailed within the evidence supporting any planning application</i></p>	<input type="checkbox"/>	<input type="checkbox"/>	<input type="checkbox"/>	<input type="checkbox"/>		
<p>Have you considered opportunities to enhance biodiversity (including enhancing existing or create new habitats and features, links to and restoration of the river, potential to create mosaics, opportunities for planting of native vegetation and trees, sustainable drainage and rain garden, and brown or green roofs and walls)?</p>	<input type="checkbox"/>	<input type="checkbox"/>	<input type="checkbox"/>	<input type="checkbox"/>		

# LDĀ DESIGN

Design Code	Applicable	Not Applicable	Complied with	Not Complied With	Please clearly set out in the column below, in which document of your application you have demonstrated compliance. (e.g. Page X of Design and Access Statement) If not complied with, please state why.	Council Confirmation and comments (Applicants Leave Free)
<i>Biodiversity, should be addressed within the evidence supporting any planning application.</i>						
<b>Built Form</b>						
New development must respond to and enhance the town centres coherent form.						
<b>B01 Scale, B02 Massing</b>						
With regard to the key characteristics of Shrewsbury, have you:	<input type="checkbox"/>	<input type="checkbox"/>	<input type="checkbox"/>	<input type="checkbox"/>		
- Appropriately considered and reflected local context (surrounding buildings and spaces) and the standards in this Design Code when considering the appropriate scale and massing of any new buildings?						
- Demonstrated how an appropriate variety in built form could be						

LDĀ DESIGN

Design Code	Applicable	Not Applicable	Complied with	Not Complied With	Please clearly set out in the column below, in which document of your application you have demonstrated compliance. (e.g. Page X of Design and Access Statement) If not complied with, please state why.	Council Confirmation and comments (Applicants Leave Free)
<p>achieved through subtle changes in height, roof line and typology?</p> <p>- Where relevant, responded to changing topography?</p> <p><i>Scale and massing should be addressed within the evidence supporting any planning application, supported by a Massing and Scale Plan which outlines proposals and the height of surrounding built form.</i></p>	<input type="checkbox"/>	<input type="checkbox"/>	<input type="checkbox"/>	<input type="checkbox"/>		
<p>Does the development achieve an appropriate density of development - having regard to local and national policy and the surrounding urban context?</p>	<input type="checkbox"/>	<input type="checkbox"/>	<input type="checkbox"/>	<input type="checkbox"/>		

LDĀ DESIGN

Design Code	Applicable	Not Applicable	Complied with	Not Complied With	Please clearly set out in the column below, in which document of your application you have demonstrated compliance. (e.g. Page X of Design and Access Statement) If not complied with, please state why.	Council Confirmation and comments (Applicants Leave Free)
<i>This should be addressed within the evidence supporting any planning application.</i>						
<b>B03 Urban Grain &amp; Articulation</b>						
With regard to the key characteristics of Shrewsbury, have you considered and appropriately responded to the urban grain of the town centre? <i>This should be addressed within the evidence supporting any planning application.</i>	<input type="checkbox"/>	<input type="checkbox"/>	<input type="checkbox"/>	<input type="checkbox"/>		
Where new development blocks are proposed, have you considered achievement of a permeable perimeter and movement corridors through built form, achievement of a continuous built edge, sub-division	<input type="checkbox"/>	<input type="checkbox"/>	<input type="checkbox"/>	<input type="checkbox"/>		

LDĀ DESIGN

Design Code	Applicable	Not Applicable	Complied with	Not Complied With	Please clearly set out in the column below, in which document of your application you have demonstrated compliance. (e.g. Page X of Design and Access Statement) If not complied with, please state why.	Council Confirmation and comments (Applicants Leave Free)
<p>into distinct buildings or the perception of such through varied massing, roof heights and roof form. <i>A plan of the proposed development block showing these considerations should form part of the evidence supporting any planning application.</i></p>						
<p><b>Identity</b> New development must demonstrate an understanding of the unique character of Shrewsbury town centre, responding to local building composition, roof form, materials and details in a sensitive contemporary way.</p>						
<p><b>I01 Local Character, I02 Composition and articulation, I03 Roof form, I04 Materials and details, I05 Windows</b></p>						
<p>With regard to the key characteristics of Shrewsbury, have you undertaken appraisal of surrounding urban character, clearly articulated the distinctive design and materials that support the areas' identity including</p>	<input type="checkbox"/>	<input type="checkbox"/>	<input type="checkbox"/>	<input type="checkbox"/>		

LDĀ DESIGN

Design Code	Applicable	Not Applicable	Complied with	Not Complied With	Please clearly set out in the column below, in which document of your application you have demonstrated compliance. (e.g. Page X of Design and Access Statement) If not complied with, please state why.	Council Confirmation and comments (Applicants Leave Free)
<p>distinctive features and details, and detailed how they are to be incorporated into the scheme? <i>This should be addressed within the evidence supporting any planning application. This can be supported by use of 3D modelling, cross sections and elevations of the proposal to illustrate how new buildings and landscape will be arranged to work with the topography of the site and the character of the surrounding area</i></p>	<input type="checkbox"/>	<input type="checkbox"/>	<input type="checkbox"/>	<input type="checkbox"/>		
<p>Has the composition and building articulation proposed been informed by due consideration of the key characteristics of Shrewsbury town</p>	<input type="checkbox"/>	<input type="checkbox"/>	<input type="checkbox"/>	<input type="checkbox"/>		

LDĀ DESIGN

Design Code	Applicable	Not Applicable	Complied with	Not Complied With	Please clearly set out in the column below, in which document of your application you have demonstrated compliance. (e.g. Page X of Design and Access Statement) If not complied with, please state why.	Council Confirmation and comments (Applicants Leave Free)
centre – including materials and details, roof form and windows. <i>This should be addressed within the evidence supporting any planning application.</i>						
<b>Public Space</b>						
The streets and spaces of Shrewsbury will be enhanced, and added to, through new development within the town centre.						
<b>P01 Public realm, P02 Safety and security, P03 Play and P04 HVM</b>						
Have opportunities to create public space within a development been considered from the outset and maximised within the design? <i>Each proposed public space should be detailed with the evidence supporting any planning application. This should include a plan identifying its key feature and phasing within the</i>	<input type="checkbox"/>	<input type="checkbox"/>	<input type="checkbox"/>	<input type="checkbox"/>		

# LDĀ DESIGN

Design Code	Applicable	Not Applicable	Complied with	Not Complied With	Please clearly set out in the column below, in which document of your application you have demonstrated compliance. (e.g. Page X of Design and Access Statement) If not complied with, please state why.	Council Confirmation and comments (Applicants Leave Free)
<i>development. Use of illustrations, precedents and visualisations can assist in articulating the intended appearance and feel of proposed public spaces.</i>	<input type="checkbox"/>	<input type="checkbox"/>	<input type="checkbox"/>	<input type="checkbox"/>		
Does the design of public spaces ensure they are inclusive and accessible for all, and adhere to the safety and security principles in this Design Code? <i>Inclusivity and safety of proposed public space should be detailed with the evidence supporting any planning application.</i>	<input type="checkbox"/>	<input type="checkbox"/>	<input type="checkbox"/>	<input type="checkbox"/>		
Has appropriate street furniture (seating, planters, art, signage, lighting etc) been integrated into any	<input type="checkbox"/>	<input type="checkbox"/>	<input type="checkbox"/>	<input type="checkbox"/>		

LDĀ DESIGN

Design Code	Applicable	Not Applicable	Complied with	Not Complied With	Please clearly set out in the column below, in which document of your application you have demonstrated compliance. (e.g. Page X of Design and Access Statement) If not complied with, please state why.	Council Confirmation and comments (Applicants Leave Free)
<p>proposed public spaces in a coherent way which minimises clutter and supports maintenance and longevity? <i>The approach to street furniture should be detailed with the evidence supporting any planning application.</i></p>						
<p><b>Uses</b> New development should contribute towards a vibrant town centre experience</p>						
<p><b>U01 Mix, U02 Active frontages</b></p>						
<p>Have proposed uses been informed by an appreciation of surrounding land use character and do they complement and enhance the offer of Shrewsbury town centre? <i>The evidence supporting any planning application should demonstrate why</i></p>	<input type="checkbox"/>	<input type="checkbox"/>	<input type="checkbox"/>	<input type="checkbox"/>		

LDĀ DESIGN

Design Code	Applicable	Not Applicable	Complied with	Not Complied With	Please clearly set out in the column below, in which document of your application you have demonstrated compliance. (e.g. Page X of Design and Access Statement) If not complied with, please state why.	Council Confirmation and comments (Applicants Leave Free)
<i>the proposed land use will enhance the land use mix within Shrewsbury</i>						
Do proposals achieve active frontages onto public streets and public realm? <i>The evidence supporting any planning application should include plans demonstrating achievement of active frontages and proposed location of main approaches and entrances to each building.</i>	<input type="checkbox"/>	<input type="checkbox"/>	<input type="checkbox"/>	<input type="checkbox"/>		
<b>Homes</b>						
New development must contribute to the delivery of high quality, accessible and sustainable housing in Shrewsbury town centre.						
<b>H01 Residential quality, H02 Gardens and balconies, H03 Detailing</b>						
Do all proposed dwellings achieve at least M4(2) accessible and adaptable dwelling standards and where there are more than 5 dwellings proposed	<input type="checkbox"/>	<input type="checkbox"/>	<input type="checkbox"/>	<input type="checkbox"/>		

LDĀ DESIGN

Design Code	Applicable	Not Applicable	Complied with	Not Complied With	Please clearly set out in the column below, in which document of your application you have demonstrated compliance. (e.g. Page X of Design and Access Statement) If not complied with, please state why.	Council Confirmation and comments (Applicants Leave Free)
do at least 5% achieve M4(3) wheelchair used dwelling standards? <i>The evidence supporting any planning application should illustrate the achievement of M4(2) and M4(3) standards. A planning condition will be used to secure this provision</i>	<input type="checkbox"/>	<input type="checkbox"/>	<input type="checkbox"/>	<input type="checkbox"/>		
Do all proposed dwellings have access to external private amenity space? <i>The evidence supporting any planning application should illustrate the approach to provision of external private amenity space. The preference is a private garden, although in some instances a balcony</i>	<input type="checkbox"/>	<input type="checkbox"/>	<input type="checkbox"/>	<input type="checkbox"/>		

# LDĀ DESIGN

Design Code	Applicable	Not Applicable	Complied with	Not Complied With	Please clearly set out in the column below, in which document of your application you have demonstrated compliance. (e.g. Page X of Design and Access Statement) If not complied with, please state why.	Council Confirmation and comments (Applicants Leave Free)
<i>and access to communal open space may be appropriate.</i>						
Do dwellings include an appropriate mix of types, sizes and tenures that respond to identified local needs? <i>The evidence supporting any planning application should illustrate the dwelling mix and explain how this responds to local need.</i>	<input type="checkbox"/>	<input type="checkbox"/>	<input type="checkbox"/>	<input type="checkbox"/>		
Has the layout of any apartments and maisonettes considered provision of natural surveillance, daylight penetration, achievement of dual or triple aspect frontages, and avoidance of single aspect northern facing apartments?						

LDĀ DESIGN

Design Code	Applicable	Not Applicable	Complied with	Not Complied With	Please clearly set out in the column below, in which document of your application you have demonstrated compliance. (e.g. Page X of Design and Access Statement) If not complied with, please state why.	Council Confirmation and comments (Applicants Leave Free)
<i>The evidence supporting any planning application should illustrate layout of dwellings and how these issues have been considered.</i>						
<p><b>Resources</b> New development within Shrewsbury town centre should be designed and developed to be climate resilient and sustainable.</p>						
<p><b>R01 Passive design and orientation, R02 Solar energy generation, R03 Windows, shading and cooling, R04 Environmental standards, R05 Retrofitting, R06 Embodied energy, R07 Operational/ whole life energy, R08 Modern methods of construction, R09 Water saving</b></p>						
Are proposals informed by consideration of optimising orientation, massing, light penetration, shading and cooling to minimise overheating?	<input type="checkbox"/>	<input type="checkbox"/>	<input type="checkbox"/>	<input type="checkbox"/>		
<i>The evidence supporting any planning application should demonstrate how these factors have been considered</i>						

LDĀ DESIGN

Design Code	Applicable	Not Applicable	Complied with	Not Complied With	Please clearly set out in the column below, in which document of your application you have demonstrated compliance. (e.g. Page X of Design and Access Statement) If not complied with, please state why.	Council Confirmation and comments (Applicants Leave Free)
<p>Does design maximise fabric energy efficiency and has consideration for zero and low carbon renewable energy generation occurred? <i>The evidence supporting any planning application should address energy efficiency and renewable energy opportunities.</i></p>	<input type="checkbox"/>	<input type="checkbox"/>	<input type="checkbox"/>	<input type="checkbox"/>		

This page is left blank.

L D Ā D E S I G N

Unit 209 Ducie House  
37 Ducie Street  
Manchester M1 2JW  
United Kingdom  
+44 (0)161 359 5684

[www.lda-design.co.uk](http://www.lda-design.co.uk)

LDA Design Consulting Ltd  
Registered No: 09312403  
17 Minster Precincts, Peterborough PE1 1XX

---

LDA Design is a ISO 9001:2015 / ISO 14001:2015  
accredited company